

TECHNICAL DOCUMENTATION



1D-HD - LIFTING SYSTEMS | THS3 **THREADED SWIVEL EYE HEAVY DUTY**

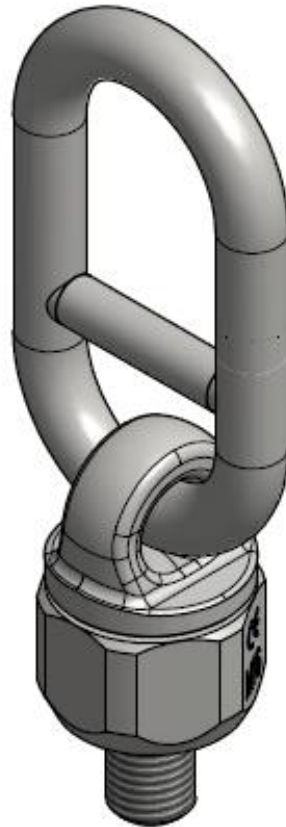

TABLE OF CONTENTS:

THREADED SWIVEL EYE – THS3	3
THS3 – APPLICATIONS	4
CHECKING THE LIFTING SYSTEM	6
STORAGE REQUIREMENTS	7
SAFETY INSTRUCTIONS	8
GENERAL INFORMATION	9
CE MARKING	11
PRODUCT RANGE	11
HD LIFTING SYSTEMS	11
TECHNICAL INFORMATION – CHOOSING THE TYPE OF ANCHOR	12
SAFETY RULES.....	12
POSSIBLE TYPES OF FAILURE OF A LIFTING ANCHOR.....	13
DIMENSIONING OF LIFTING ANCHOR SYSTEM.....	14
LOAD CAPACITY.....	15
WEIGHT OF PRECAST UNIT.....	15
ADHESION TO FORMWORK COEFFICIENT.....	15
DYNAMIC LOADS COEFFICIENT.....	16
LIFTING OF PRECAST CONCRETE ELEMENT UNDER COMBINED TENSION AND SHEAR LOADING.....	16
ASYMMETRIC DISTRIBUTION OF THE LOAD.....	17
ANCHORS LIFTING CONDITIONS.....	17
LOAD DIRECTIONS.....	19
POSITIONING THE ANCHORS IN WALLS.....	20
DETERMINATION OF ANCHOR LOAD.....	21
INSTALLATION TOLERANCES FOR ALL TERWA LIFTING SOCKET ANCHORS.....	21
CALCULATION EXAMPLE	22
EXAMPLE 1: SLAB UNIT.....	22
EXAMPLE 2: WALL PANEL.....	23
EXAMPLE 3: DOUBLE-T BEAM.....	24
CONTACT	25
DISCLAIMER	25

THREADED SWIVEL EYE – THS3

The threaded swivel eye can be used for anchors with threaded sockets and are suitable for most lifting situations, particularly for turning and tilting. They are more suitable for turning and tilting than the lifting systems manufactured from steel wire and can be reused provided they are inspected regularly. If kept in storage for reuse, they must be inspected in accordance with local requirements. The threaded swivel eye THS3 anchors are made of high-quality steel and are designed with a safety factor of 5. Every lifting system is individually tested at 3 times the working load and comes with its own unique certificate.

The threaded swivel eye should only be attached to the concrete unit and used after the concrete strength has reached 15 MPa. It is usually removed after the concrete elements have been installed. This lifting system is suitable for use with threaded socket cast that is flush with the surface of the unit or recessed using (KU-10, TPM) recess formers.

Ensure that the thread is engaged all the way to the bottom of the socket before lifting.

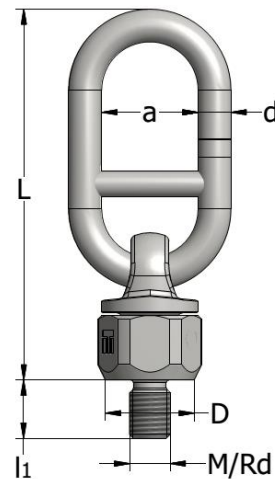
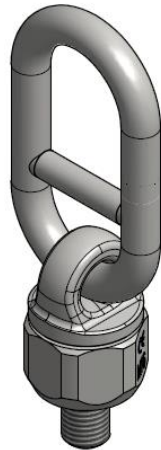

THS3-M	Product no.	Thread	Load group	Axial load	L	a	d	D	l ₁
		M	[t]	[kN]	[mm]	[mm]	[mm]	[mm]	[mm]
THS3-HD-M12	61703	12	1.3	13	124	34	11	30	17
THS3-HD-M16	61704	16	2.5	25	145	38	13	35	23
THS3-HD-M20	61705	20	4.0	40	169	45	15	44	28.5
THS3-HD-M24	62748	24	5.0	50	198	49	17	44	33.5
THS3-HD-M30	62749	30	7.5	75	230	60	20	59	44.5
THS3-HD-M36	62750	36	10.0	100	264	64	24	59	53.5
THS3-HD-M42	62751	42	12.5	125	285	68	26	75	57.5
THS3-HD-M52	60828	52	15.0	150	307	72	31	84	67.5

THS3-Rd	Product no.	Thread	Load group	Axial load	L	a	d	D	l ₁
		Rd	[t]	[kN]	[mm]	[mm]	[mm]	[mm]	[mm]
THS3-HD-Rd12	61706	12	1.3	13	124	34	11	30	17
THS3-HD-Rd16	61707	16	2.5	25	145	38	13	35	23
THS3-HD-Rd20	61708	20	4.0	40	169	45	15	44	28.5
THS3-HD-Rd24	62752	24	5.0	50	198	49	17	44	33.5
THS3-HD-Rd30	62753	30	7.5	75	230	60	20	59	44.5
THS3-HD-Rd36	62754	36	10.0	100	264	64	24	59	53.5
THS3-HD-Rd42	62755	42	12.5	125	285	68	26	75	57.5
THS3-HD-Rd52	60829	52	15.0	150	307	72	31	84	67.5

THS3 – APPLICATIONS

SCREWING DETAILS

Ensure that the thread is fully bottomed out in the socket before lifting. **No gaps are permitted between the concrete element and the body of the lifting system: the thread must be fully threaded inside the socket.**

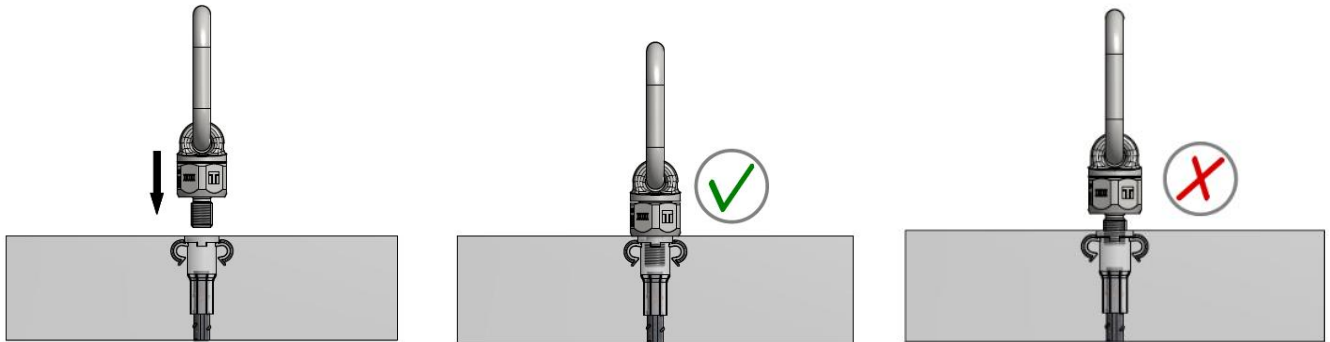

The preferred option is the vertical lift. Normally the angle of lift (β) should not be greater than 30° . Pulling back towards the unit is not permitted.

ADMISSIBLE LOAD DIRECTION

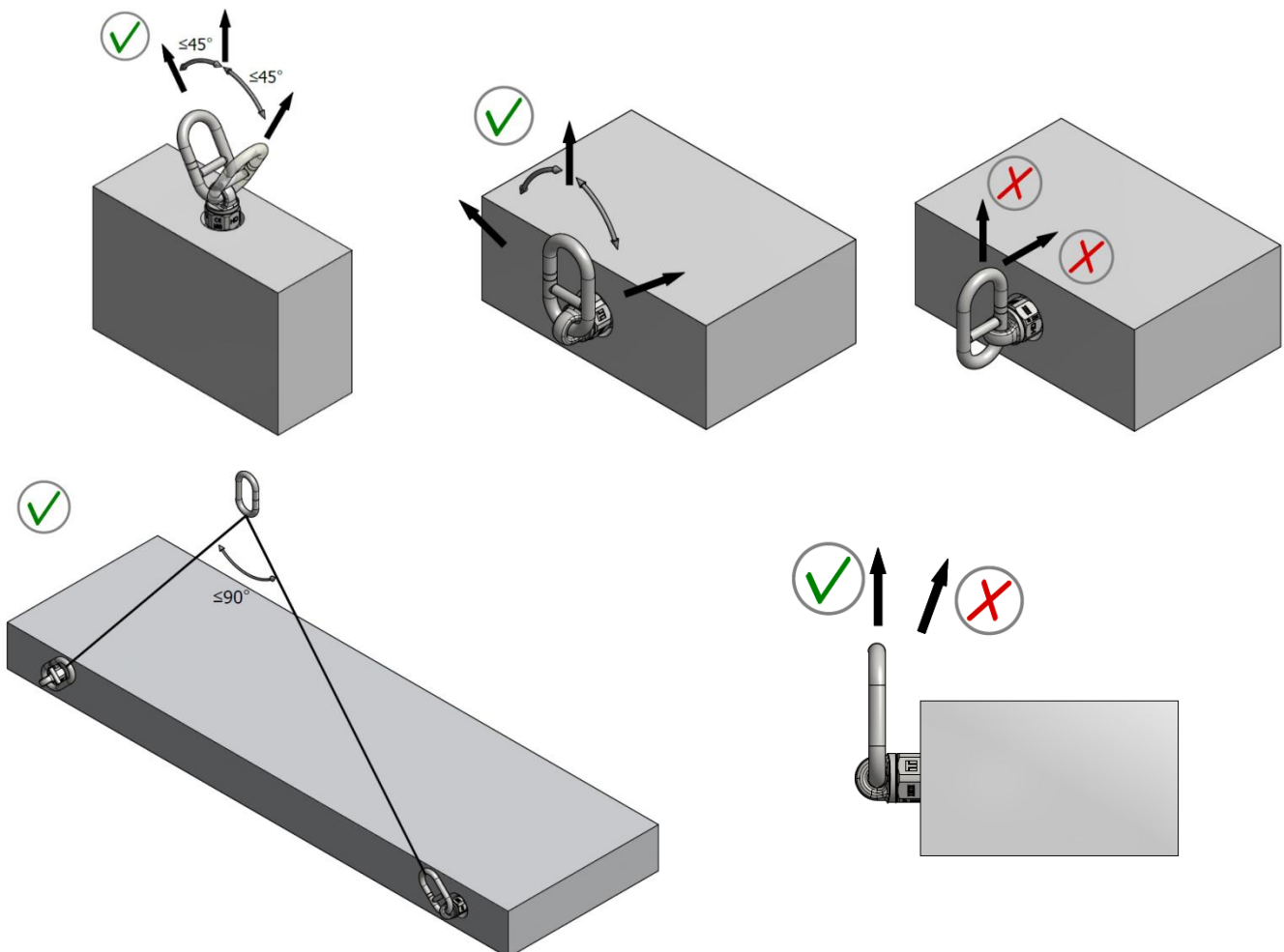

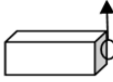
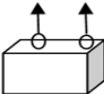
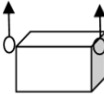
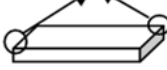
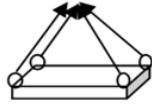
Number of pieces	1	1	2	2	2	2	3 or 4	3 or 4
Type of attachment								
Angle of inclination	0 °	90 °	0 °	90 °	0 ° - 45 °	45 ° - 60 °	0 ° - 45 °	45 ° - 60 °
THS3-M/Rd	WLL group	Axial load	Load group	Axial load	Load group	Axial load	Load group	Axial load
	[kN]	[kN]	[kN]	[kN]	[kN]	[kN]	[kN]	[kN]
THS3-M/Rd12	13	6.5	26	13	9.1	6.5	13	9.1
THS3-M/Rd16	25	12.5	50	25	17.5	12.5	25	17.5
THS3-M/Rd20	40	20.0	80	40	28.0	20.0	40	28.0
THS3-M/Rd24	50	25.0	100	50	35.0	25.0	50	35.0
THS3-M/Rd30	75	37.5	150	75	52.5	37.5	75	52.5
THS3-M/Rd36	100	50.0	200	100	70.0	50.0	100	70.0
THS3-M/Rd42	125	62.5	250	125	84.0	62.5	125	84.0
THS3-M/Rd52	150	75.0	300	150	105.0	75.0	150	105.0

For an asymmetrical load distribution, the lifting capacities applicable to the 2 and 3 or 4 leg slings are the same as for 1 leg types at 90°.

The preferred option is the vertical lift. Normally, the angle of lift (β) should not be greater than 30°. Pulling back towards the unit is not permitted.

GENERAL GUIDANCE FOR LIFTING THS1 AND THS3

Ensure that the concrete has MPa strength of at least 15 before beginning lifting.

For positioning the inserts, always check the permitted edge distances and spacing between inserts.

We recommend restricting the lift angle to a maximum of 30° when an angled lift is necessary.

To choose the proper lifting system, take into consideration how frequently the precast unit is going to be lifted.

The cast-in threaded elements (anchors or fixing inserts) can be flush or recessed for corrosion protection.

This recess is filled with fine concrete after use.

All the HD lifting systems are tested before delivery under a test load three times the working load (individual test for THS1 and THS3).

CHECKING THE LIFTING SYSTEM

The lifting devices THS1 and THS3 must be examined by the authorised specialist before using the first time, at least twice a year and after special events.

- **Any deformation to the wire rope (see the type of damages mentioned on the following page), oval link, thread, or metal structural elements causes a weakening of the lifting device with the risk of falling of the precast element. Do not perform any repair work. The lifting device must be discarded. Lifting loops with broken strands or other signs of damage, kinking, bird caging, corrosion that require discarding according EN 13414-1 must not be used for any further lifting.**
- **Damage, distortions, cracks and extensive corrosion can reduce the load-carrying capacity and lead to failure. This causes a hazard to life and limb. If necessary, any affected parts must be taken out of service immediately.**

The lifting bolt thread must be regularly checked for signs of damage. Re-cutting the thread is not permitted. Cables must not come into contact with acids, caustic solutions or other aggressive substances.

Combining products from different companies is not recommended.

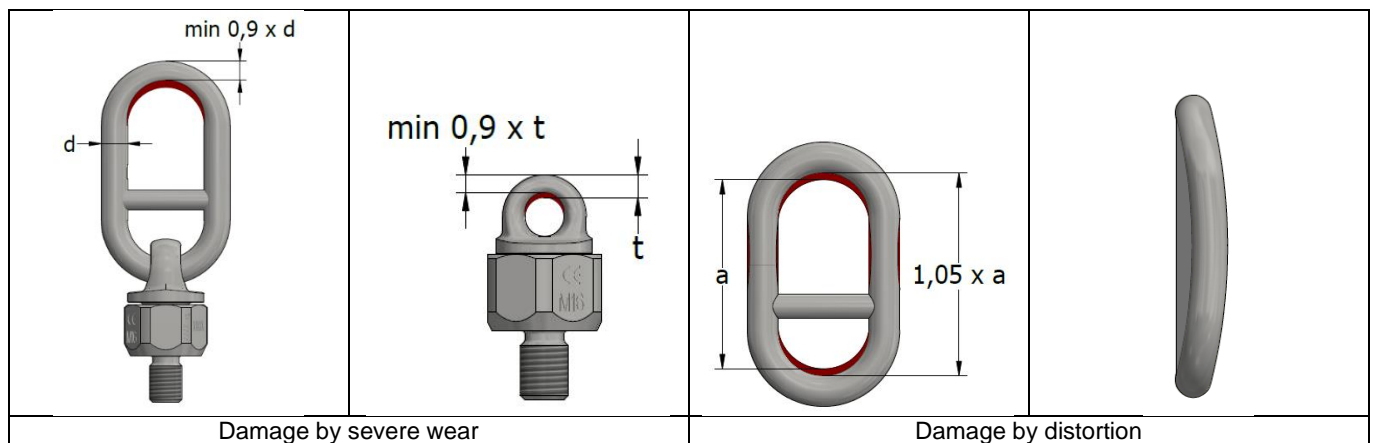

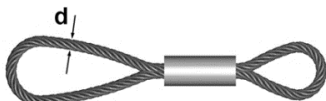





	Cable type	Number of visible broken wires over a length of		
		3d	6d	10d
	Stranded rope	4	6	16

d = cable diameter

Wire cables should be inspected and discarded according EN 13414-1 when the following flaws occur:

- Kinking
- One strand is broken
- Separation of the outer layer of braids
- Crushed strands
- Crushing at the shackle contact point with more than 4 ruptured wires on braided cables or more than 10 ruptured wires on cable-laid rope
- Signs of corrosion
- Damage to or severe wear of the closing bush.
- Signs of slipping between the cable and the closing bush
- A cable with several broken wires mentioned in the table above must be taken out of use

Wire rope dimensions		
		
Kinking	Severe wear	Bird caging
		
Broken wire	Corrosion	Closing bush damage

STORAGE REQUIREMENTS

Lifting systems and anchors must be stored and protected in dry conditions, under a roof. Large temperature variations, snow, ice, humidity, or salt and salt water impact may cause damage to anchors and shorten the service life.

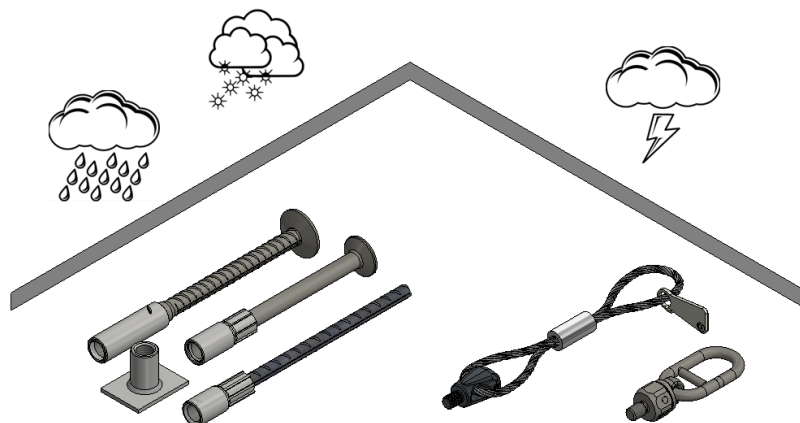

SAFETY INSTRUCTIONS

Warning: Use only trained personnel. Use the anchor and the lifting device by untrained personnel poses the risk of incorrect use or falling, which may cause injury or death. The lifting systems must be used only for lifting and moving precast concrete elements.

Obligatory instructions for safe working:

- All lifting anchors and lifting devices must be operated manually
- Visually inspect lifting anchors before use; check and clean all lifting inserts prior to use
- Hook in all lifting systems separately, without using force

Respect local regulations for safe lifting and hoisting at all times.

Incorrect use may result in safety hazards and reduced load-carrying capacity. This may cause the lifted object to fall and pose a hazard to life and limb. Lifting anchor systems must be used only by suitable trained personnel.

GENERAL INFORMATION

HD threaded lifting systems are used in the precast industry and are suitable for lifting, transporting and installing precast concrete elements on site.

Some of the advantages of this system include:

- a wide range of lifting sockets
- capability of establishing a connection in a safe, simple manner
- the lifting systems can be re-used.
- CE conforming system. All Terwa lifting systems have the CE marking which guarantees conformance with the European regulations

The threaded lifting system combines a lifting anchor embedded in a concrete unit and a lifting device.

The design for Terwa threaded lifting anchors and technical instructions comply with the national German guideline VDI/BV-BS6205 "Lifting inserts and lifting insert for precast concrete elements". Based on this guideline, the manufacturer must also ensure that the lifting systems have enough strength to prevent concrete failure.

A failure of lifting anchors and lifting anchor devices can endanger human lives as well as can lead to significant damage. Therefore, lifting anchors and lifting devices must be produced with high quality, carefully selected and which are designed for the respective application and used by skilled personnel according to lifting and handling instructions.

Quality

Terwa continuously controls the anchor production process in terms of strength, dimensional and material quality, and performs all of the required inspections for a superior quality system. All of the products are tracked from material acquisition to the final, ready to use product.



Marking and traceability

All anchors and lifting clutches have the CE marking and all data necessary for traceability, thread type and load class.

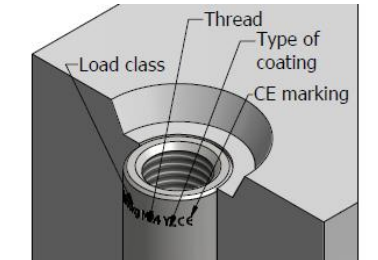
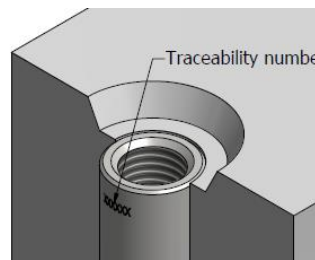

Anchor testing

Terwa lifting anchors are designed to resist at a minimum safety factor of **3x load group**

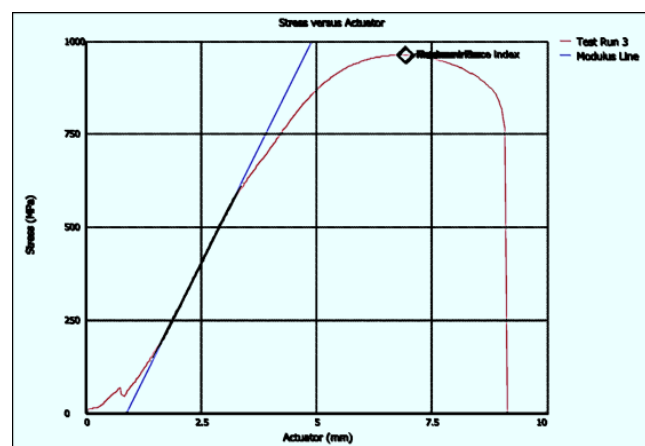

Application of lifting anchor system

Load carrying devices - are equipment that is permanently connected to the hoist for attaching lifting devices, lifting accessory or loads.

Lifting accessory – equipment that creates a link between the load carrying device and the lifting device.

Lifting device (lifting key) – equipment that connects the loads to the load carrying device by means of lifting accessories.

Lifting anchor – steel part embedded in the concrete element, which is intended as an attachment point for the lifting device.

Lifting anchor system - consists of a lifting anchor (insert), which is permanently anchored in the precast concrete element and the corresponding lifting device, which is temporarily fixed to the embedded lifting anchor.

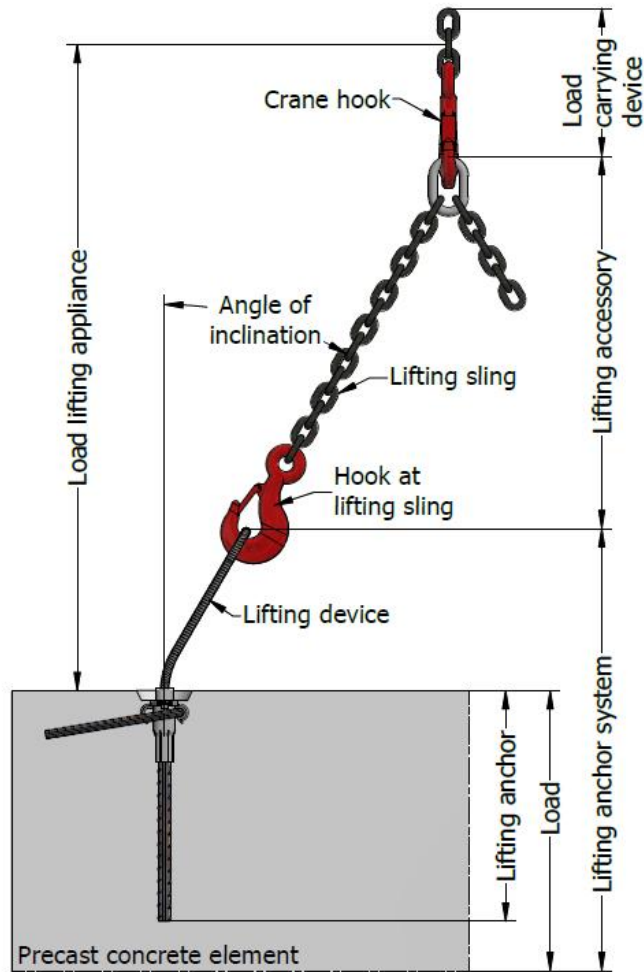

Interaction between the parts of the series of guidelines VDI/BV-BS 6205

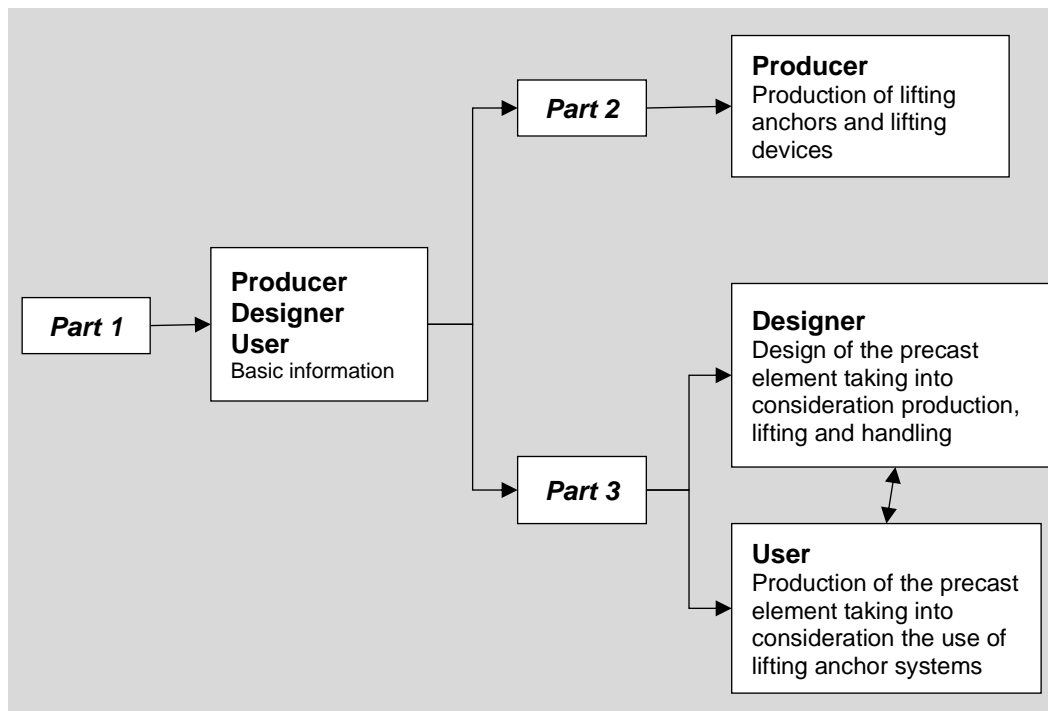

CE MARKING

CE marking means that a product is manufactured and inspected in accordance with a harmonised European standard (hEN) or a European Technical Approval (ETA). ETA can be used as the basis for CE marking for cases in which there is no harmonised EN standard. However, ETA is voluntary and not required by EU directives or legislation.

Manufacturers may use the CE marking to declare that their construction products meet harmonised European standards or have been granted ETA Approvals. These documents define properties the products must have to be granted the right to use the CE marking and describe how the manufacture of these products is supervised and tested.

EU Construction Products Regulation takes full effect on 1 July 2013. There are no harmonised EN standards for detailed building parts, such as connections used in concrete constructions, excluding lifting items and devices, which are covered by the EU Machinery Directive. For steel constructions, CE marking will become mandatory as of 1 July 2014, as covered by the EU Construction Products Directive.

PRODUCT RANGE

HD LIFTING SYSTEMS

- RE-USABLE THREADED LIFTING SYSTEM**
 Terwa offers various types of threaded lifting keys suitable for lifting, transporting and installing precast concrete elements.
- TRANSPORT ANCHORS**
 T-tail and rebar anchors with pressed sockets designed for lifting and transporting various precast concrete elements with a load range between 1.3 and 15 tonnes and lifting sockets with footplate suitable for thin panels or top slabs.
- RECESS FORMERS AND MOUNTING ACCESSORIES**
 Mounting accessories for fixing the anchors to the formwork during the production of the precast element.

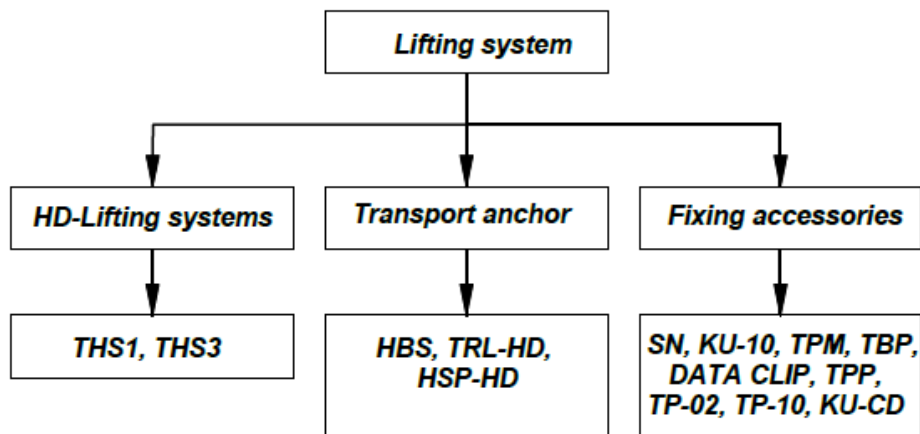
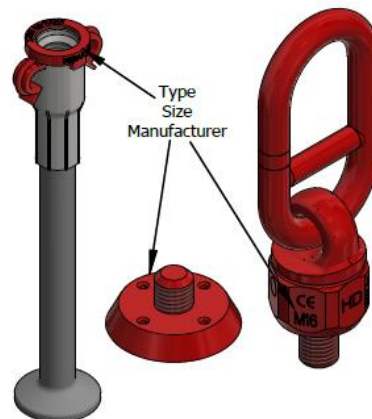

TECHNICAL INFORMATION – CHOOSING THE TYPE OF ANCHOR

Terwa has 3 types of lifting systems:

- 1D threaded lifting system
- 2D strip anchor lifting system
- 3D T-slot anchor lifting system

The method for choosing the anchor is identical for all these types and depends on the lifting method and/or experience.

The 1D threaded lifting system is mainly used when the hoisting angles are limited, while the 2D strip anchor lifting system and the 3D T-slot anchor lifting system can be used for all hoisting angles, with minor limitations for the 2D strip anchor lifting system. The difference between the 2D strip anchor lifting system and the 3D T-slot anchor lifting system lies principally in the experience one has in using one or the other system.

Terwa also has software for making the anchor calculations.



SAFETY RULES

The lifting system consists of a threaded anchor embedded in concrete and a threaded lifting device. The threaded lifting loop is connected to the anchor only when required for lifting. **Ensure that the concrete has reached MPa strength of at least 15 before beginning lifting.**

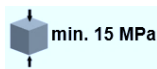

These lifting systems are not suitable for **intensive** re-use. Please see chapter **Checking the lifting system** for inspection requirements.

In designing the lifting system, the safety factors for the failure mode steel rupture derived from the Machinery Directive 2006/42/EC are:

- **for steel component (solid sections)** $\gamma = 3$
- **for steel wires** $\gamma = 4$

For this, the load-side dynamic working coefficient $\psi_{dyn} = 1.3$

For the determination of the characteristic resistances based on method A in accordance with DIN EN 1990 - Annex D for the concrete break-out, splitting, blow-out and pull-out failure modes, the safety factor is $\gamma = 2.5$

The safety concept requires that the action E does not exceed the admissible value for the resistance R_{adm} :

$$E \leq R_{adm} \quad \text{Where: } E - \text{action, } R_{adm} - \text{admissible load (resistance)}$$



The admissible load (resistance) of lifting anchor and lifting device is obtained as follows:

$$R_{adm} = \frac{R_k}{\gamma} \quad \text{Where: } R_k - \text{characteristic resistance of the anchoring of a lifting anchor or lifting device, } \gamma - \text{global safety factor}$$

Notice: The lifting anchors must always be installed above the centre of gravity. Otherwise, the element can tip over during transport.

The maximum permitted load on the components quoted in the tables has been obtained by applying a safety factor on test data.

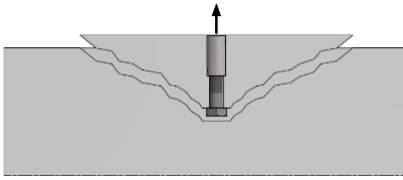
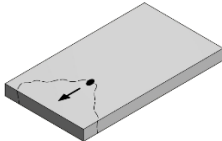
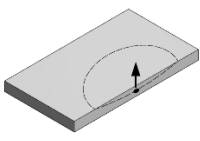
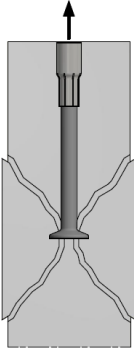
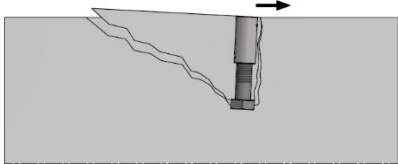
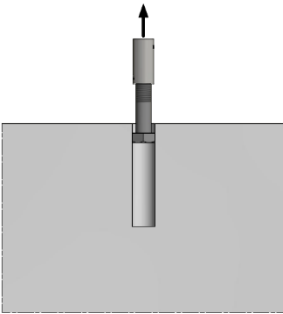
POSSIBLE TYPES OF FAILURE OF A LIFTING ANCHOR

Failure type	Fracture pattern: tensile force	Fracture pattern: transverse shear force	
<p>Concrete break-out Failure mode, characterised by a wedge or cone shaped concrete break-out body, which was separated from the anchor ground and is initiated by the lifting anchor</p>			
<p>Local concrete break-out (blow-out) Concrete spalling at the side of the component that contains the anchor, at the level of the form-fitting load application by the lifting anchor into the concrete break-out at the concrete surface.</p>			
<p>Pry-out (rear breakout of concrete) Failure mode characterised by the concrete breaking out opposite the direction of load, on lifting anchors with shear load.</p>			
<p>Pull-out Failure mode, where the lifting anchor under tension load is pulled out of the concrete with large displacements and a small concrete break-out.</p>			
<p>Splitting of the component A concrete failure in which the concrete fractures along a plane passing through the axis of the lifting anchor.</p>			

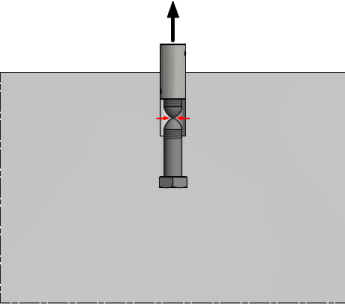
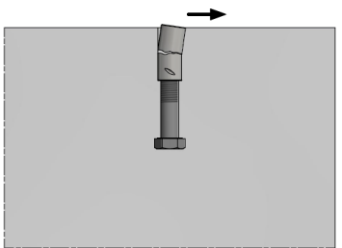
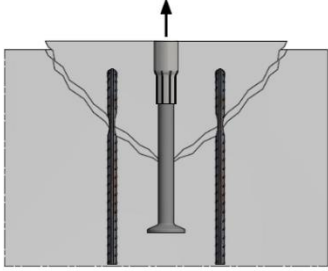
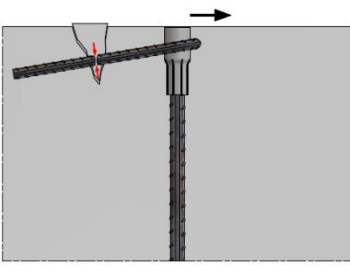
Failure type	Fracture pattern: tensile force	Fracture pattern: transverse shear force
Steel failure Failure mode characterised by fracture of the steel lifting anchor parts.		
Steel failure of additional reinforcement Steel failure of the supplementary reinforcement loaded directly or indirectly by the lifting anchor		

DIMENSIONING OF LIFTING ANCHOR SYSTEM

For the safe dimensioning of lifting anchor systems for precast concrete elements, the following points must be made clear at the start:

- The type of the structural element and the geometry
- Weight and location of centre of gravity of the structural element
- Directions of the loads on the anchor during the entire transport process, with all loading cases that occur.
- The static system of taking on the loads.

To determine the correct size of lifting anchor, the stresses in the direction of the wire rope sling must be determined for all load classes. These stresses must then be compared with the applicable resistance values for the type of loading case.

Stress ≤ Resistance always applies

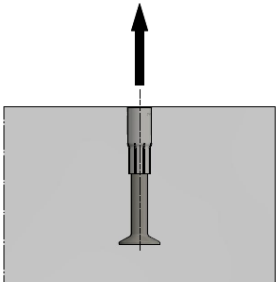
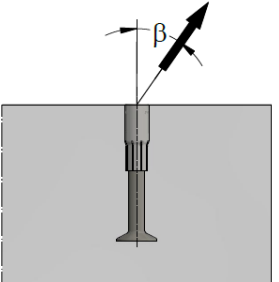
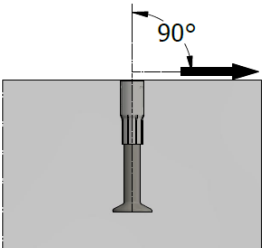
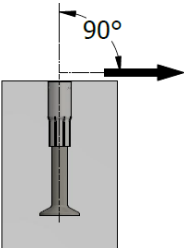
<i>Direction of stress</i>			
<i>Axial tension</i>		<i>Parallel shear pull</i>	
Load or load component action in the direction of the longitudinal axis of the lifting anchor.		Load or load component action at an angle β to the longitudinal axis of the lifting anchor in the plane of the precast component.	
<i>Transverse shear pull parallel to the structural element plane</i>		<i>Transverse shear pull perpendicular to the structural element plane</i>	
Load or load component parallel to the surface of structural element and to the plane of the element, acting at an angle β perpendicular to the longitudinal axis of the lifting anchor.		Load or load component parallel to the building component surface and perpendicular to the surface of the component.	

LOAD CAPACITY

The loading and capacity of the anchors depend on multiple factors such as:

- The deadweight of the precast concrete element “ F_G ”
- Adhesion to the formwork
- The load direction, angle of pull
- Number of load bearing anchors
- The edge distance and spacing of the anchors
- The strength of the concrete when operating, lifting or transporting
- The embedded depth of the anchor
- Dynamic forces
- The reinforcement arrangement

WEIGHT OF PRECAST UNIT

The total self-weight “ F_G ” of the precast reinforced concrete element is determined using a specific weight of: $\rho = 25\text{kN/m}^3$. For prefabricated elements composed of reinforcing elements with a higher concentration, this will be taken into consideration when calculating the weight.

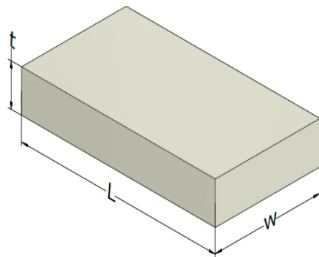

$$F_G = \rho \times V$$

$$V = L \times w \times h$$

Where:

V - volume of precast unit in $[\text{m}^3]$

L - length in $[\text{m}]$

w - width in $[\text{m}]$

h - thickness in $[\text{m}]$

ADHESION TO FORMWORK COEFFICIENT

When a precast element is lifted from the formwork, adhesion force between element and formwork develops. This force must be taken into consideration for the calculation of the anchor load and depends on the total area in contact with the formwork, the shape of the precast element and the material of the formwork. The value “ F_{adh} ” of adhesion to the formwork is calculated using the following equation:

$$F_{adh} = q_{adh} \times A_f \text{ [kN]}$$

Where: F_{adh} - action due to adhesion and form friction, in kN

q_{adh} - the adhesion to formwork and form friction factor corresponding to the material of the formwork

A_f - the area of contact between the formwork and the concrete element when starting the lift

Adhesion to the formwork	q_{adh} in kN/m^2
Oiled steel formwork, oiled plastic-coated plywood	≥ 1
Varnished timber formwork with panel boards	≥ 2
Rough timber formwork	≥ 3

In some cases, such as π - panel or other specially shaped elements, an increased adhesion coefficient must be taken into consideration.

Adhesion to the formwork	
Double-T beams	$F_{adh} = 2 \times F_G \text{ [kN]}$
Ribbed elements	$F_{adh} = 3 \times F_G \text{ [kN]}$
Waffled panel	$F_{adh} = 4 \times F_G \text{ [kN]}$

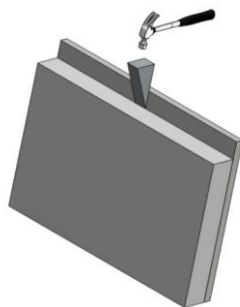

Adhesion to the formwork should be minimised before lifting the concrete element out of the formwork by removing as many parts of the formwork as possible.

Before lifting from the table, the adhesion to the formwork must be reduced as much as possible by removing the formwork from the concrete element (tilting the formwork table, brief vibration for detachment, using wedges).

DYNAMIC LOADS COEFFICIENT

During lifting and handling of the precast elements, the lifting devices are subject to dynamic actions. The value of the dynamic actions depends on the type of lifting machinery. Dynamic effect shall be considered by the dynamic factor Ψ_{dyn} .

Lifting equipment	Dynamic factor Ψ_{dyn}
Tower crane, portal crane and mobile crane	1.3 *)
Lifting and moving on flat terrain	2.5
Lifting and moving on rough terrain	≥ 4.0

*) lower values may be appropriate in precast plants if special arrangements are made.

For special transport and lifting cases, the dynamic factor is established based on the tests or on proven experience.

LIFTING OF PRECAST CONCRETE ELEMENT UNDER COMBINED TENSION AND SHEAR LOADING

The load value applied on each anchor depends on the chain inclination, which is defined by the angle β between the normal direction and the lifting chain.

The cable angle β is determined by the length of the suspension chain. We recommend that, if possible, β should be kept to $\beta \leq 30^\circ$. The tensile force on the anchor will be increased by a cable angle coefficient "z".

$$z = 1/\cos\beta$$

$$F = \frac{F_{tot} \times z}{n}$$

Where:

z - cable angle coefficient

n - number of load bearing anchors

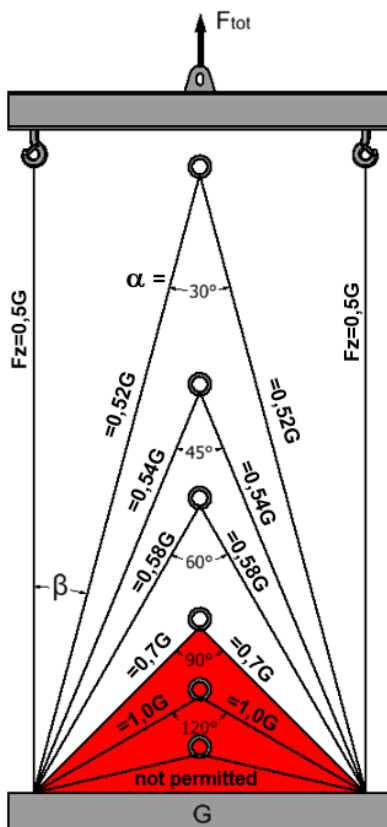

Cable angle β	Spread angle a	Cable angle factor z
0°	-	1.00
7.5°	15°	1.01
15.0°	30°	1.04
22.5°	45°	1.08
30.0°	60°	1.16
*37.5°	75°	1.26
*45.0°	90°	1.41

* preferred $\beta \leq 30^\circ$

Note: If no lifting beam is used during transport, the anchor must be embedded symmetrical to the load.

ASYMMETRIC DISTRIBUTION OF THE LOAD

For asymmetrical elements, calculate the loads based on the centre of gravity before installing the anchors.
 The load of each anchor depends on the embedded position of the anchor in the precast unit and on the transport mode:

- a) If the arrangement of the anchors is asymmetrical in relation to the centre of gravity, the individual anchors support different loads. For the load distribution in asymmetrally installed anchors when a spreader beam is used, the forces on each anchor are calculated using the following equation:

$$F_a = F_{tot} \times b / (a + b)$$

$$F_b = F_{tot} \times a / (a + b)$$

Note: To avoid tilting the element during transport, the load should be suspended from the lifting beam in such a way that its centre of gravity (Cg) is directly under the crane hook.

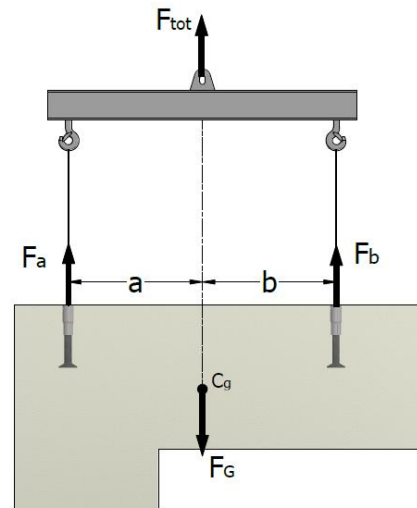

- b) For transporting without a lifting beam, the load on the anchor depends on the cable angle (β).

ANCHORS LIFTING CONDITIONS

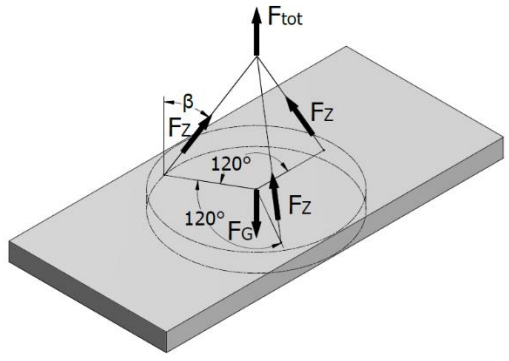
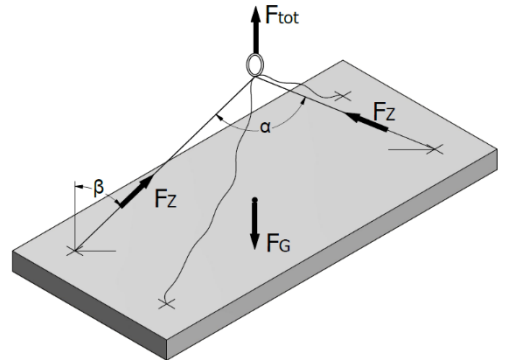
<p>Using three anchors spaced the same distance apart from each other as in the figure, three load bearing anchors can be assumed. Load bearing anchors: n=3 Load type – lifting of formwork -shear pull factor $z \geq 1$ -formwork adhesion -no dynamic factor</p> <p>Load type – transport -shear pull factor $z \geq 1$ -no formwork adhesion -dynamic factor</p>	
<p>Using four anchors lifted without a spreader beam, only two load bearing anchors can be assumed. The load distribution is randomly based Load bearing anchors: n=2 Load type – lifting of formwork -shear pull factor $z \geq 1$ -formwork adhesion -no dynamic factor</p> <p>Load type – transport -shear pull factor $z \geq 1$ -no formwork adhesion -dynamic factor</p>	

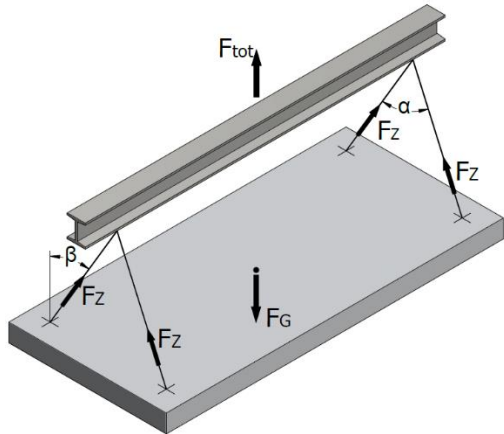
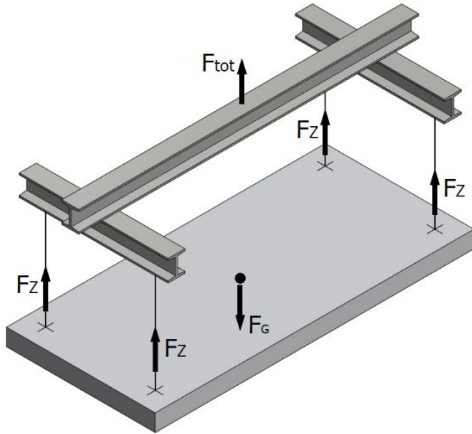
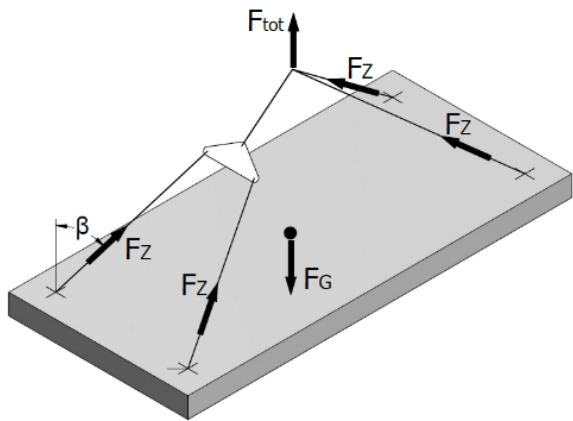
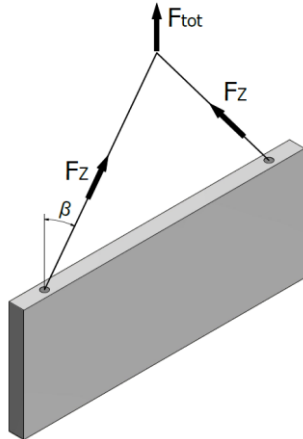
<p>Perfect force distribution is assumed using a spreader beam Load bearing anchors: n=4 Load type – lifting of formwork -shear pull factor $z \geq 1$ -formwork adhesion -no dynamic factor</p> <p>Load type – transport -shear pull factor $z \geq 1$ -no formwork adhesion -dynamic factor</p>	
<p>Perfect static weight distribution can be obtained using a lifting beam and two pairs of anchors symmetrically placed. Load bearing anchors: n=4 Load type – lifting of formwork -shear pull factor $z \geq 1$ -formwork adhesion -no dynamic factor</p> <p>Load type – transport -shear pull factor $z \geq 1$ -no formwork adhesion -dynamic factor</p>	
<p>The compensating lifting slings ensure equal force distribution. Load bearing anchors: n=4 Load type – lifting of formwork -shear pull factor $z \geq 1$ -formwork adhesion -no dynamic factor</p> <p>Load type – transport -shear pull factor $z \geq 1$ -no formwork adhesion -dynamic factor</p>	
<p>Lifting of wall elements parallel to the axis of concrete element Load bearing anchors: n=2 Load type – transport -shear pull factor $z \geq 1$ -no formwork adhesion -dynamic factor</p>	

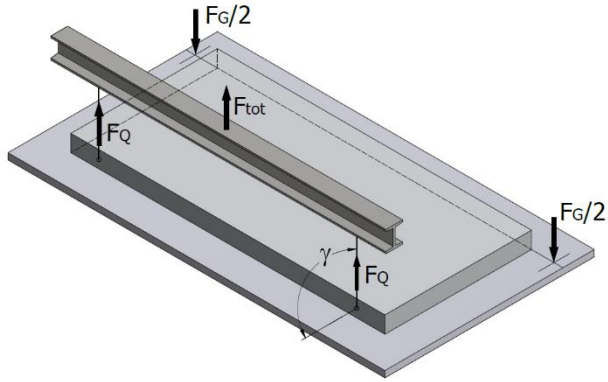
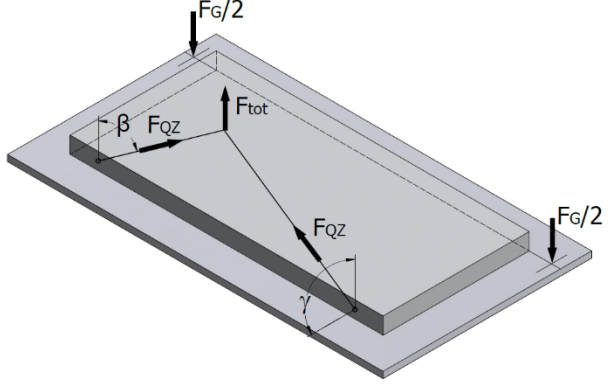
<p>When the element is lifted without a lifting table at a straight angle and contact with the ground is maintained. Additional shear reinforcement is required. Load bearing anchors: n=2 Load type – lifting of formwork -shear pull factor $z = 1$ -formwork adhesion -no dynamic factor</p> <p>Load type – transport -shear pull factor $z = 1$ -no formwork adhesion -dynamic factor</p>	
<p>When the element is lifted without a lifting table at a straight angle and contact with the ground is maintained. Additional shear reinforcement is required. $\beta \leq 30^\circ$ Load bearing anchors: n=2 Load type – lifting of formwork -shear pull factor $z \geq 1$ -formwork adhesion -no dynamic factor</p> <p>Load type – transport -shear pull factor $z \geq 1$ -no formwork adhesion -dynamic factor</p>	

LOAD DIRECTIONS

Various scenarios may occur during transport and lifting, such as tilt-up, rotation, hoisting and, of course, installation. The lifting anchors and clutches must have the capacity for all these cases and combinations of them. Therefore, the load direction is a very important factor for proper anchor selection.

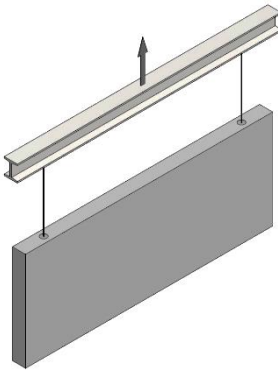
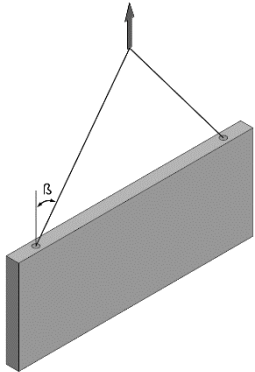
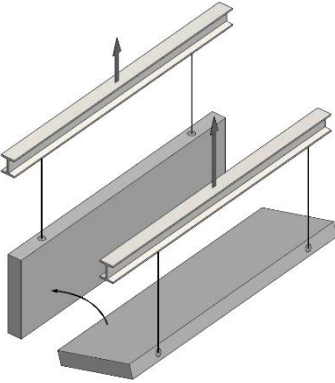
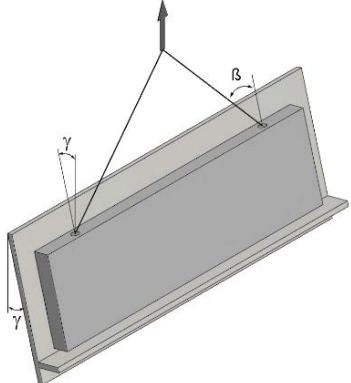
<p>Axial load $\beta = 0^\circ$ to 10°</p> 	<p>Diagonal load $\beta = 10^\circ$ to 45°</p> <p>Note: $\beta \leq 30^\circ$ is recommended</p> 
<p>Tilting $g = 90^\circ$</p> <p>Additional shear reinforcement steel must be used.</p> 	<p>When a tilting table is used, the anchors can be used without additional shear reinforcement steel, not to angle $g < 15^\circ$</p> 

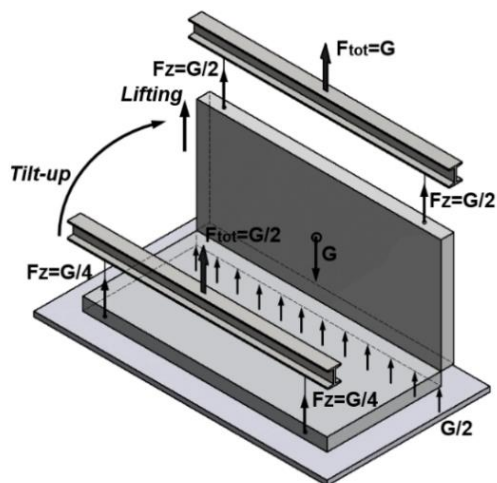
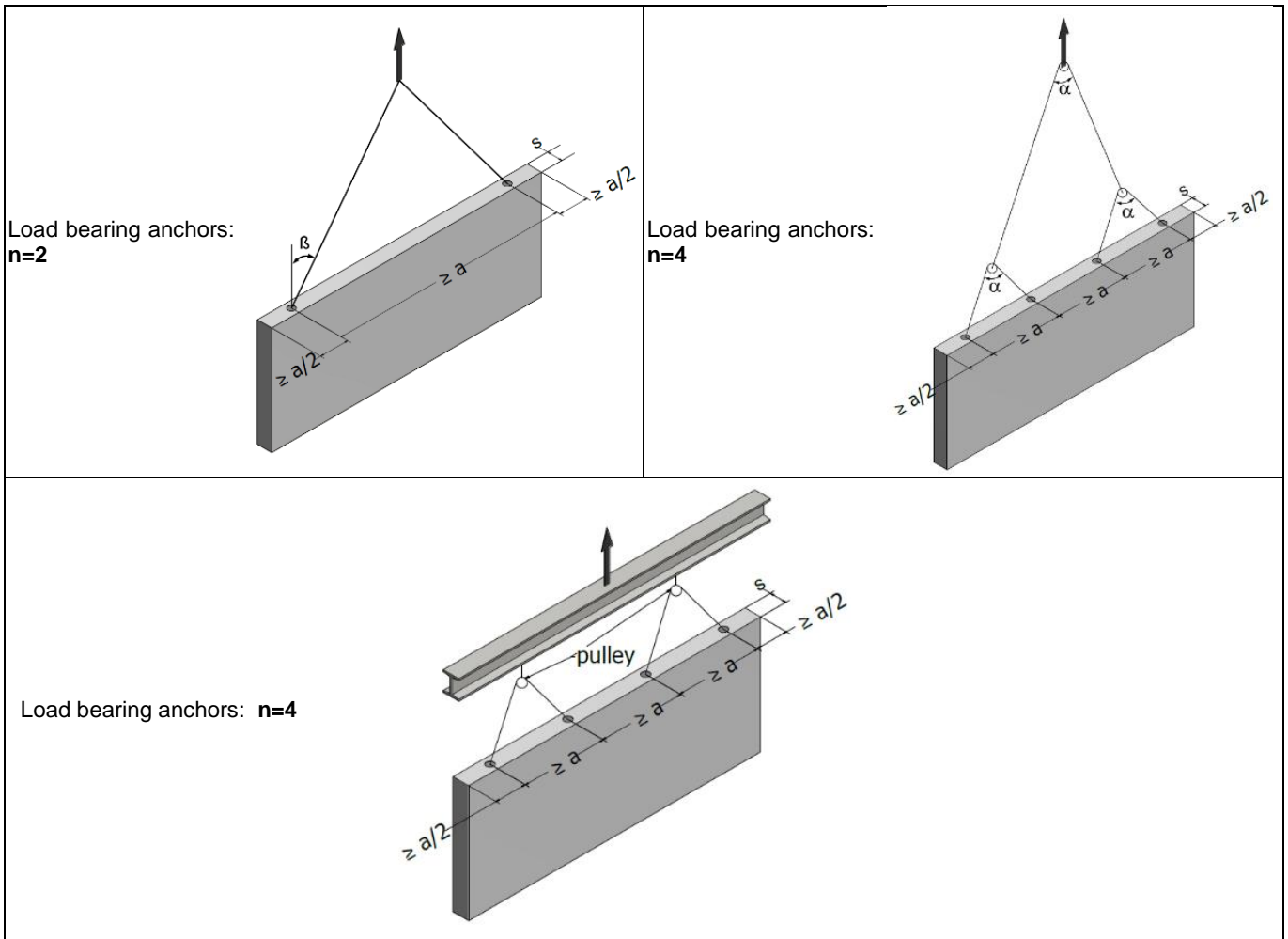
POSITIONING THE ANCHORS IN WALLS

Lifting the walls from horizontal to vertical position without tilt-up table.

In this case, the anchors are loaded with half of the element weight, since half of the element remains in contact with the casting table.

DETERMINATION OF ANCHOR LOAD

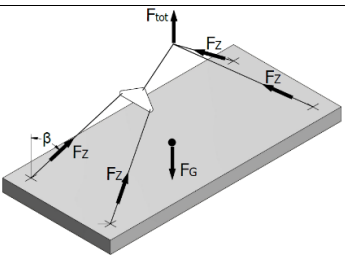
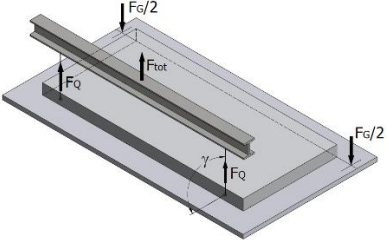
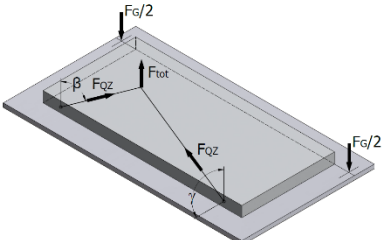
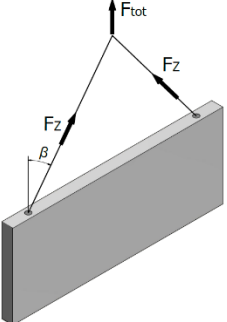
	Load type	Calculation	Verification
Lifting with formwork adhesion		$F_Z = \frac{(F_G + F_{adh}) \times z}{n}$ <p>F_Z – Load acting on the lifting anchor in kN</p>	$F_Z \leq N_{R,adm}$ <p>$N_{R,adm}$ – admissible normal load</p>
Erecting		$F_Q = \frac{(F_G/2) \times \psi_{dyn}}{n}$ <p>F_Q – Shear load acting on the lifting anchor directed perpendicular to the longitudinal axis of the concrete element when lifting from horizontal position with a beam in kN</p>	$F_Q \leq V_{R,adm}$ <p>$V_{R,adm}$ – admissible shear load</p>
		$F_{QZ} = \frac{(F_G/2) \times \psi_{dyn} \times z}{n}$ <p>F_{QZ} – Shear load acting on the lifting anchor inclined and perpendicular to the longitudinal axis of the concrete element when lifting from horizontal position with a beam in kN</p>	$F_{QZ} \leq V_{R,adm}$ <p>$V_{R,adm}$ – admissible shear load</p>
Transport		$F_Z = \frac{F_G \times \psi_{dyn} \times z}{n}$ <p>F_Z – Load acting on the lifting anchor in kN</p>	$F_Z \leq N_{R,adm}$ <p>$N_{R,adm}$ – admissible normal load</p>

INSTALLATION TOLERANCES FOR ALL TERWA LIFTING SOCKET ANCHORS

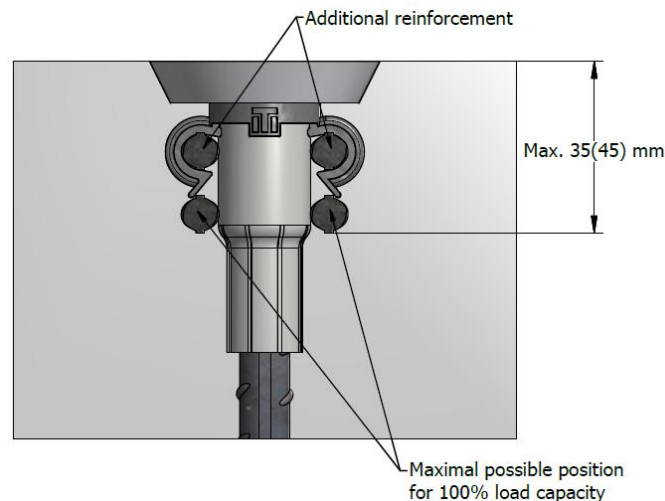

CALCULATION EXAMPLE

Example 1: SLAB UNIT

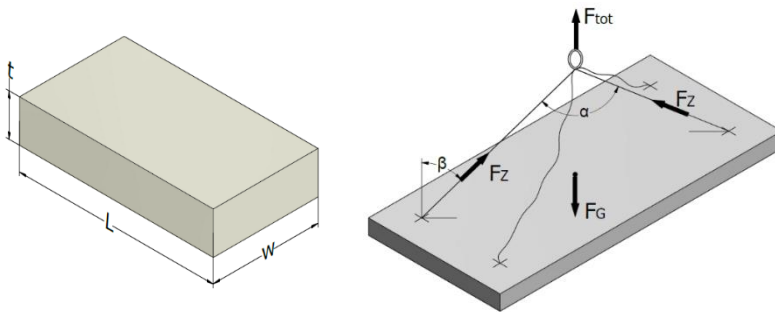

The slab unit has the following dimensions:

$$L = 5 \text{ m}$$

$$w = 2 \text{ m}$$

$$t = 0.2 \text{ m}$$

$$\text{Weight } F_G = \rho \times V = 25 \times (5 \times 2 \times 0.2) = 50 \text{ kN}$$

$$\text{Formwork area } A_f = L \times w = 5 \times 2 = 10 \text{ m}^2$$

$$\text{Anchor number } n = 2$$

General data:	Symbol	De-mould	Transport	Mount
Concrete strength at de-mould [MPa]		15	15	
Concrete strength on site [MPa]				35
Element weight [kN]	F_G	50		
Element area in contact with formwork [m ²]	A_f	10		
Cable angle factor at de-mould ($\beta = 15.0^\circ$)	z	1.04	1.04	
Cable angle factor on site ($\beta = 30.0^\circ$)	z			1.16
Dynamic coefficient at transport	Ψ_{dyn}		1.3	
Dynamic coefficient on site	Ψ_{dyn}			1.3
Adhesion to formwork factor for varnished timber formwork [kN/m ²]	q_{adh}	2		
Anchor number for de-mould	n	2		
Anchor number for transport at the plant	n		2	
Anchor number for transport on site	n			2

DE-MOULD AT THE PLANT:

Adhesion to formwork factor: $q_{adh} = 2 \text{ kN/m}^2$
 Cable angle factor: $z = 1.04 (\beta = 15.0^\circ)$
 Concrete strength: 15 MPa

$$F_Z = \frac{[(F_G + q_{adh} \times A_f) \times z]}{n} = \frac{[(50 + 2 \times 10) \times 1.04]}{2} = 36.4 \text{ kN}$$

TRANSPORT AT THE PLANT:

Dynamic coefficient: $\Psi_{dyn} = 1.3$
 Cable angle factor: $z = 1.04 (\beta = 15.0^\circ)$
 Concrete strength: 15 MPa

$$F_Z = \frac{F_G \times \Psi_{dyn} \times z}{n} = \frac{50 \times 1.3 \times 1.04}{2} = 33.80 \text{ kN}$$

TRANSPORT ON SITE:

Dynamic coefficient: $\Psi_{dyn} = 1.3$
 Cable angle factor: $z = 1.16 (\beta = 30.0^\circ)$
 Concrete strength: 35 MPa

$$F_Z = \frac{F_G \times \Psi_{dyn} \times z}{n} = \frac{50 \times 1.3 \times 1.16}{2} = 37.70 \text{ kN}$$

An anchor in the 40 kN range is required.

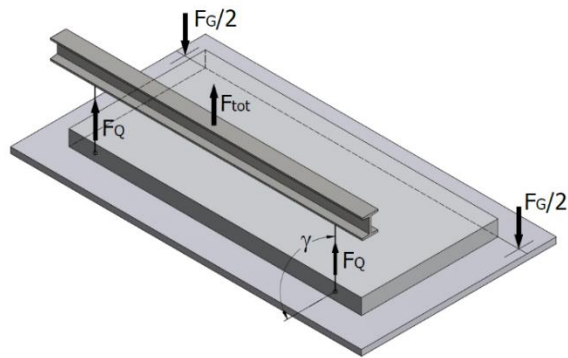
Example 2: WALL PANEL

The slab unit has the following dimensions:

$$L = 7.5 \text{ m}$$

$$w = 2 \text{ m}$$

$$t = 0.18 \text{ m}$$

$$\text{Weight } F_G = \rho \times V = 25 \times (7.5 \times 2 \times 0.18) = 67.5 \text{ kN}$$

$$\text{Formwork area } A_f = L \times w = 7.5 \times 2 = 15 \text{ m}^2$$

$$\text{Anchor number } n = 2$$

General data:	Symbol	De-mould	Tilting	Mount
Concrete strength at de-mould [MPa]		15	15	
Concrete strength on site [MPa]				45
Element weight [kN]	F_G	67.5		
Element area in contact with formwork [m ²]	A_f	15		
Cable angle factor at de-mould ($\beta = 0.0^\circ$)	z	1.0		
Cable angle factor at tilting ($\beta = 0.0^\circ$)	z		1.0	
Cable angle factor on site ($\beta = 30^\circ$)	z			1.16
Dynamic coefficient at tilting	Ψ_{dyn}		1.3	
Dynamic coefficient on site	Ψ_{dyn}			1.3
Adhesion factor for oiled steel formwork [kN/m ²]	q_{adh}	1.0		
Anchor number for de-mould	n	2		
Anchor number at tilting	n		2	
Anchor number for transport on site	n			2

DE-MOULD / TILT-UP AT THE PLANT:

Adhesion to formwork factor: $q_{adh} = 1 \text{ kN/m}^2$
 Cable angle factor: $z = 1 (\beta = 0^\circ)$
 Concrete strength: 15 MPa

$$F_Q = \frac{[(F_G/2 + q_{adh} \times A_f) \times z]}{n} = \frac{[(67.5/2 + 1 \times 15) \times 1]}{2} = 24.38 \text{ kN}$$

TRANSPORT AT THE PLANT:

Dynamic coefficient: $\Psi_{dyn} = 1.3$
 Cable angle factor: $z = 1 (\beta = 0^\circ)$
 Concrete strength: 15 MPa

$$F_Q = \frac{F_G \times \Psi_{dyn} \times z}{n} = \frac{67.5 \times 1.3 \times 1}{2} = 43.87 \text{ kN}$$

TRANSPORT ON SITE:

Dynamic coefficient: $\Psi_{dyn} = 1.3$
 Cable angle factor: $z = 1.16 (\beta = 30.0^\circ)$
 Concrete strength: 35 MPa

$$F_Q = \frac{F_G \times \Psi_{dyn} \times z}{n} = \frac{67.5 \times 1.3 \times 1.16}{2} = 50.89 \text{ kN} = 51 \text{ kN}$$

For embedding on the lateral side, two anchors in the 75kN range are required.
 Tail and tilting reinforcement are usually added for this type of anchor reinforcement.

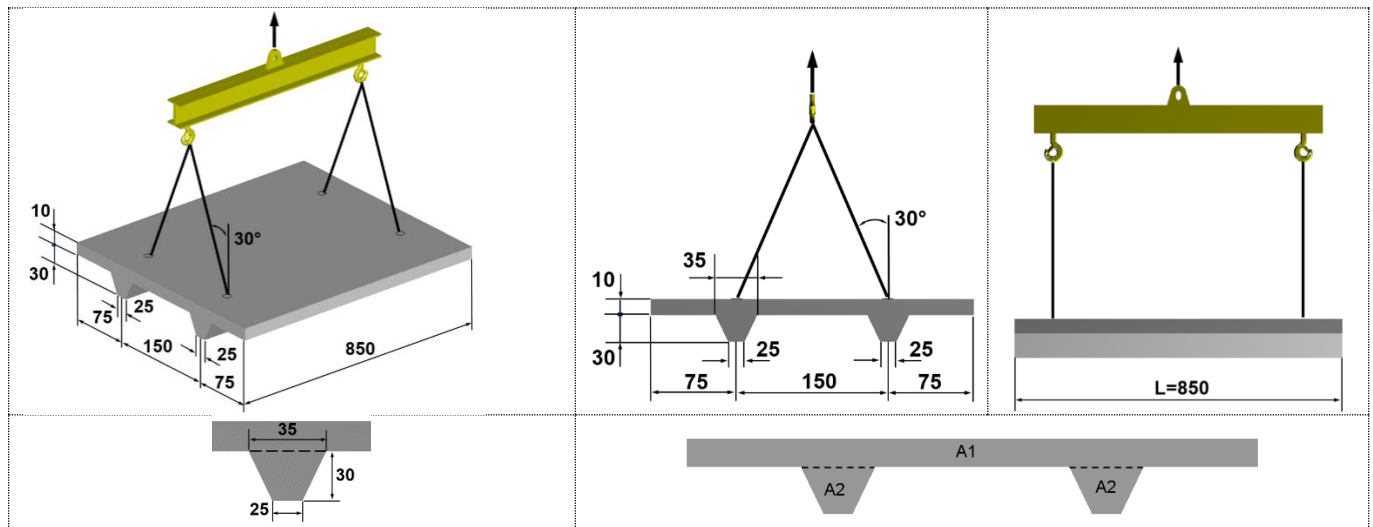
Example 3: DOUBLE-T BEAM

NOTE: Dimensions are in cm

General data:	Symbol	De-mould	Transport
Concrete strength at de-mould and transport [MPa]		25	25
Element weight [kN]	F_G	102	
Formwork area [m ²]	A_f	35.8	
Cable angle factor at de-mould ($\beta = 30.0^\circ$)	z	1.16	
Cable angle factor on site ($\beta = 30.0^\circ$)	z		1.16
Dynamic coefficient at transport	ψ_{dyn}		1.3
Anchor number for de-mould and transport	n	4	4

Load capacity when lifting and transporting at the manufacturing plant.

Concrete strength when de-mould	≥ 25 MPa
Cable angle factor	$z = 1.16$ ($\beta = 30.0^\circ$)
Dynamic coefficient	$\psi_{dyn} = 1.3$
Anchor number	$n = 4$

$$F_G = V \times \rho = (A \times L) \times \rho = (A1 + A2 \times 2) \times L \times \rho = (0.1 \times 3 + 0.09 \times 2) \times 8.5 \times 25 = 102 \text{ kN}$$

$$L = 8.5 \text{ m}$$

$$A1 = 0.1 \times 3 \text{ (m}^2\text{)}$$

$$A2 = \frac{[(0.35 + 0.25) \times 0.3]}{2} = \frac{(0.6 \times 0.3)}{2} = 0.09 \text{ (m}^2\text{)}$$

Weight:	$F_G = 102 \text{ kN}$
Adhesion to mould	$F_{adh} = 2 \times F_G = 204 \text{ kN}$
Total load	$F_{tot} = F_G + F_{adh} = 102 + 204 = 306 \text{ kN}$

LOAD PER ANCHOR WHEN DE-MOULD:

$$F = \frac{F_{tot} \times z}{n} = \frac{[(F_G + F_{adh}) \times z]}{n} = \frac{306 \times 1.16}{4} = 88.74 \text{ kN}$$

LOAD PER ANCHOR WHEN TRANSPORTING:

$$F = \frac{F_{tot} \times \psi_{dyn} \times z}{n} = \frac{F_G \times \psi_{dyn} \times z}{n} = \frac{102 \times 1.3 \times 1.16}{4} = 38.46 \text{ kN}$$

Four anchors in the 100 kN range are required (> 88.74 kN)

CONTACT



TERWA is the global supplier for precast and construction solutions with multiple offices around the world. With all our staff, partners and agents, we are happy to provide all construction and precast companies who work in the building industry with full service and 100% support.

TERWA CONSTRUCTION GROUP

Terwa Construction Netherlands (HQ)

Global Sales & Distribution
Kamerlingh Onneslaan 1-3
3401 MZ IJsselstein
The Netherlands
T +31-(0)30 699 13 29
F +31-(0)30 220 10 77
E info@terwa.com

Terwa Construction Central East Europe

Sales & Distribution
Strada Sânzieni
507075 Ghimbav
Romania
T +40 372 611 576
E info@terwa.com

Terwa Construction Poland

Sales & Distribution
Ul. Cicha 5 lok. 4
00-353 Warszawa
Poland
E info@terwa.com

Terwa Construction India & Middle East

Sales & Distribution
India
T +91 89 687 000 41
E info@terwa.com

Terwa Construction China

Sales & distribution
5F 504, No. 101 Chuanchang road
PRC, 200032, Shanghai
China
E info@terwa.com

ALL SPECIFICATIONS CAN BE CHANGED WITHOUT PREVIOUS NOTICE.

DISCLAIMER

Terwa B.V. is not liable for deviations due to wear of the products it has delivered. Neither is Terwa B.V. liable for damage due to inaccurate and/or improper handling and use of the products it has delivered and/or use of same for purposes other than those intended.

Terwa B.V.'s responsibility is furthermore limited in accordance with article 13 of the "Metaalunie" conditions, which are applicable for all Terwa B.V. deliveries. The user is responsible for ensuring compliance with all applicable copyright laws. Without limiting the rights under copyright, no part of this documentation may be reproduced, stored in or introduced into a retrieval system, or transmitted in any form or by any means (electronic, mechanical, photocopying, recording, or otherwise), or for any purpose, without the express written permission of Terwa B.V.