

Series A19A/A19B/A19D

Thermostats for Refrigeration, Cooling, Heating, Ventilation and Air-conditioning

Introduction

These thermostats are designed for refrigeration, cooling, heating, ventilation and air-conditioning applications. Standard models are provided for remote sensing or room sensing. Models with manual reset are available for low or high limit functions.

Description

These thermostats are available with fixed or adjustable differential. The various control ranges cover a broad range of temperature applications with a minimum number of models. On request a built-in high or low limit stop is possible and can be adjusted quickly and easily in the field. All models have a universal way of adjustment. For this purpose a knob and sealing cap are enclosed.

All A19 style 1 wholesaler code models have a bulb clamp plus screw also enclosed.



A19A capillary thermostat
A19B space thermostat

Feature and Benefits

<input type="checkbox"/> Liquid filled sensing element	No cross ambient temperature problems Contact differential over the whole range
<input type="checkbox"/> Dust tight Penn switch	Prevents pollution of the contacts by electrostatic influences.
<input type="checkbox"/> Trip free manual reset	Override is not possible in the control function
<input type="checkbox"/> Front adjustment	Less mounting space required.

Note

These controls are designed for use only as operating controls. Where an operating control failure would result in personal injury or loss of property it is the responsibility of the installer to add devices or systems that protect against, or warn of, control failure.

SPDT contacts are standard on all models. Instruments have compact sizes. Types A19ACC and A19ADC have a trip-free manual reset. Reset button must be pressed and released. Contact cannot be blocked in closed position. All types have VDE and SEV approval.

To facilitate ordering, wholesaler codes have been added on some universal models. All models are provided with a separate knob and sealing cap.

Type number matrix

A19AAC	capillary thermostat, fixed differential.
A19AAF	capillary thermostat, special close fixed differential.
A19ABC	capillary or immersion thermostat, adjustable differential.
A19ACC	capillary thermostat, lock-out low with manual reset.
A19ADC	immersion thermostat, lock-out high with manual reset.
A19BAC	space thermostat, fixed differential.
A19BBC	space thermostat, adjustable differential.
A19DAC	strap-on thermostat.
A19DAF	strap-on thermostat

Adjustment

- Models "set low" (refer to cover label)
The dial indicates the low switch point (1 - 2 open, 1 - 3 closed).
The high switch point (1 - 2 closed, 1 - 3 open) is obtained by adding the differential to the low switch point.
- Models "set high" (refer to cover label)
The dial indicates the high switch point (1 - 2 closed, 1 - 3 open). The low switch point (1 - 2 open, 1 - 3 closed) is obtained by deducting the differential from the high switch point.

Exception: Type A19ADC, dial indicates high switch point (1 - 3 closed, 1 - 2 open).

Note

The standard screwdriver adjustment can be converted easily in the field to knob adjustment. Also concealing of adjustment and scale is possible after installation.

Contact functions

Types A19AAC,
A19AAF, A19ABC,
A19BAC, A19BBC,
A19DAC

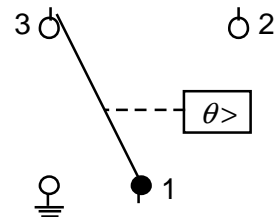

Fig. 1

1-2 closes on temperature increase

Type A19ACC

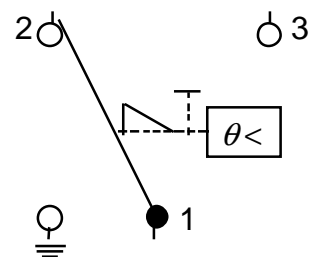

Fig. 2

1-2 opens on temperature decrease

Type A19ADC

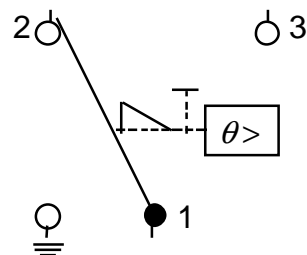

Fig.3

1-2 opens on temperature increase

Repair and replacement

Repair is not possible. In case of an improperly functioning control, please check with your nearest supplier. When contacting the supplier for a replacement you should state the type/model number of the control. This number can be found on the data plate or cover label.

Sensor styles

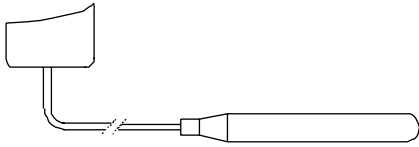

Fig. 4
Style 1a (drawn bulb)

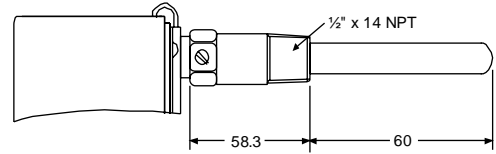

Fig. 7
Style 2

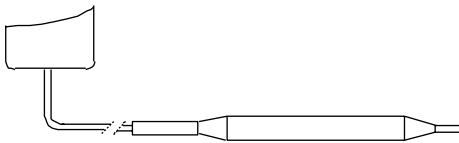

Fig. 5
Style 1b swaged bulb, can be used with closed-tank connector FTG13A-600

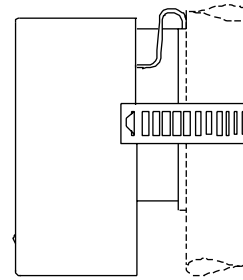

Fig. 8
Style 20

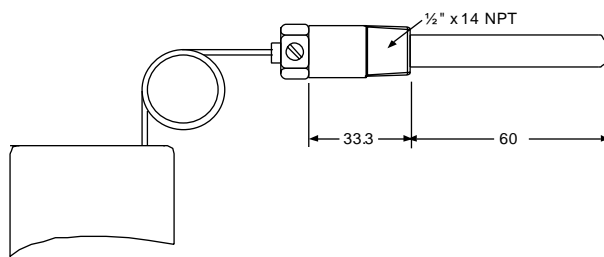

Fig. 6
Style 4h

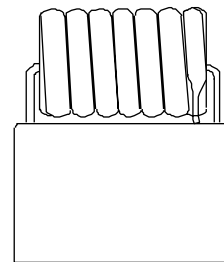

Fig. 9
Style 3 (coil)

Bulb size and finish, bulb wells

Range (°C)	Style	Bulb size (mm)	Finish	Bulb well (optional)
-35 to +10	1b	9.5 x 110	Tin-plated	WEL14A602R
-35 to +10	3	-	Stainless Steel	-
-5 to +28	1b	9.5 x 135	Tin-plated	WEL14A603R
-5 to +28	3	-	Stainless Steel	-
-35 to +40	1b	9.5 x 110	Tin-plated	WEL14A602R
-35 to +40	3	-	Stainless Steel	-
0 to 13	1a	9.3 x 80	-	WEL16A601R
0 to 43	3	-	Stainless Steel	-
1 to 60	1b	9.5 x 115	-	WEL14A602R
5 to 32	1b	9.5 x 155	Tin-plated	No bulb well available
10 to 95	1a	7.4 x 75	-	WEL11A601R
40 to 120	1b	9.5 x 100	-	WEL14A602R
35 to 150	1a	5 x 265	-	No bulb well or closed tank connector possible
90 to 290	1a	5 x 155	-	No bulb well or closed tank connector possible

Type number selection table:

Range (°C)	Diff. (K)	Bulb style	Setting (see page 2 adjustment)	Cap. length	Max. bulb temp.	Wholesaler code	Order number
------------	-----------	------------	---------------------------------	-------------	-----------------	-----------------	--------------

Type A19AAC Capillary thermostat, fixed differential

-35 to +10	2.5	1b	set low	2 m	60 °C		A19AAC-9102
-5 to +28	2	1b	set low	2 m	60 °C		A19AAC-9005
-5 to +28	2	1b	set low	5 m	60 °C		A19AAC-9124
1 to 60	2	1b	set low	3 m	85 °C		A19AAC-9127
40 to 120	3.5	1b	set high	2 m	145 °C		A19AAC-9009
35 to 150	4	1a	set high	2 m	180 °C		A19AAC-9107
90 to 290	5.5	1a	set high	2 m	290 °C		A19AAC-9108

Type A19ABC Capillary or immersion thermostat, adjustable differential

-35 to +40	2.8 to 8	1b	set low	3.5 m	60 °C	A19-A4	A19ABC-9037
-35 to +40	2.8 to 8	1b	set low	6.5 m	60 °C	A19-A5	A19ABC-9036
-35 to +10	2.8 to 11	1b	set low	2 m	60 °C	A19-A1	A19ABC-9103
-5 to +28	2 to 8	1b	set low	2 m	60 °C	A19-A2	A19ABC-9104
1 to 60	2 to 8	1b	set low	5 m	85 °C		A19ABC-9117
1 to 60	2 to 8	1b	set low	3 m	85 °C	A19-A3	A19ABC-9116
10 to 95	3.5 to 13	1a	set high	3.5 m	115 °C		A19ABC-9106
40 to 120	3.5 to 13	2	set high	-	145 °C		A19ABC-9011 bulb well incl.
40 to 120	3.5 to 13	4h	set high	2 m	145 °C		A19ABC-9012 bulb well incl.

Type A19ACC Capillary thermostat, lock-out low with manual reset

-35 to +10	6 ↘	1b	set low	2 m	60 °C		A19ACC-9100
-35 to +10 ✖	6 ↘	1b	set low	3.5 m	60 °C		A19ACC-9105
-35 to +10 ✖	6 ↘	1b	set low	5 m	60 °C		A19ACC-9111
-35 to +10 ✖	6 ↘	1b	set low	6.5 m	60 °C	A19-F	A19ACC-9116
-5 to +28	4 ↘	1b	set low	2 m	60 °C		A19ACC-9101
-5 to +28	4 ↘	1b	set low	5 m	60 °C		A19ACC-9103
-5 to +28	4 ↘	1b	set low	3 m	60 °C		A19ACC-9107

Type A19ADC immersion thermostat, lock-out high with manual reset

40 to 120	7 ↗	2	set high	-	145 °C		A19ADC-9200 bulb well incl.
-----------	-----	---	----------	---	--------	--	---------------------------------------

Type A19AAF Capillary thermostat, close, fixed differential

0 to 10	1.5	1a	set low	2 m	80 °C		A19AAF-9101
0 to 10	1.5	1a	set low	2 m	80 °C	A19-M †	A19AAF-9102
5 to 32	0.75	1b	set high	2 m	60 °C		A19AAF-9103

↘ Indicates temperature increase above cut-out point to make reset possible.

✖ Low limit stop factory set +2.5 °C may be removed in the field.

↗ Indicates temperature decrease below cut-out point to make reset possible.

† Milk-cooler thermostat.

*T*ype number selection table:

Range (°C)	Diff. (K)	Bulb style	Setting (see page 2 adjustment)	Cap. length	Max. bulb temp.	Wholesaler code	Order number
----------------	--------------	---------------	---------------------------------------	----------------	-----------------------	--------------------	-----------------

Type A19BAC Space thermostat, fixed differential

-35 to +10	2.5	3	set low	-	60 °C	A19-B1	A19BAC-9250
-5 to +28	2	3	set low	-	60 °C	A19-B2	A19BAC-9251
0 to 43	2	3	set high	-	60 °C	A19-B3	A19BAC-9001

Type A19BBC Space thermostat, adjustable differential

-35 to +40	2.8/8	3	set low	-	60 °C	A19-B4	A19BBC-9275
------------	--------------	---	---------	---	-------	--------	--------------------

Type A19DAC, Strap-on thermostat, fixed differential

40 to 120	4.5	20	set high	-	145°C		A19DAC-9001
92 to 116	2	20	set high	-	145°C		A19DAF-9001

Note: If what you need is not in the type number selection table, then please contact your representative.

Accessories (optional)

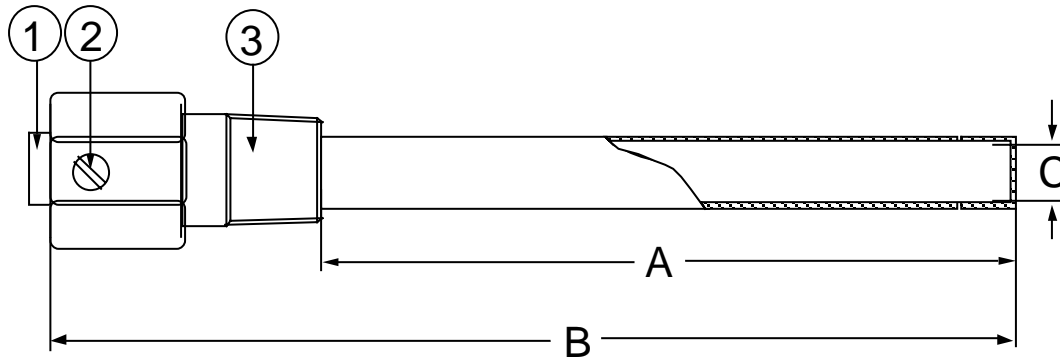

Order no.	Dimension A	Dimension B	Dimension C Internal
WEL11A601R	60 mm	118 mm	7.3 mm
WEL14A602R	125 mm	171 mm	9.8 mm
WEL14A603R	147 mm	193 mm	9.8 mm
WEL16A601R	71 mm	117 mm	9.5 mm

1. Bushing
2. Set screw
3. Adapter, 1/2"-14 NPT

Fig. 10
Bulb well (brass, copper pipe)

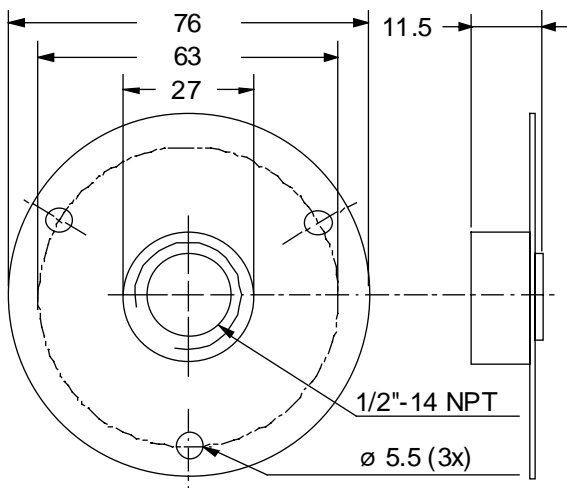
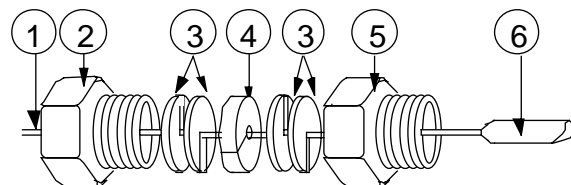

Fig. 11
Duct flange to be used with closed-tank connector FTG13A-600R.
Order number T-752-1001



1. Style 1b bulb support tube
2. Packing nut
3. Washer
4. Packing
5. Adapter, 1/2"-14 NPT
6. Bulb

Fig. 12
Closed-tank connector
Order number FTG13A-600R

Dimensions (mm)

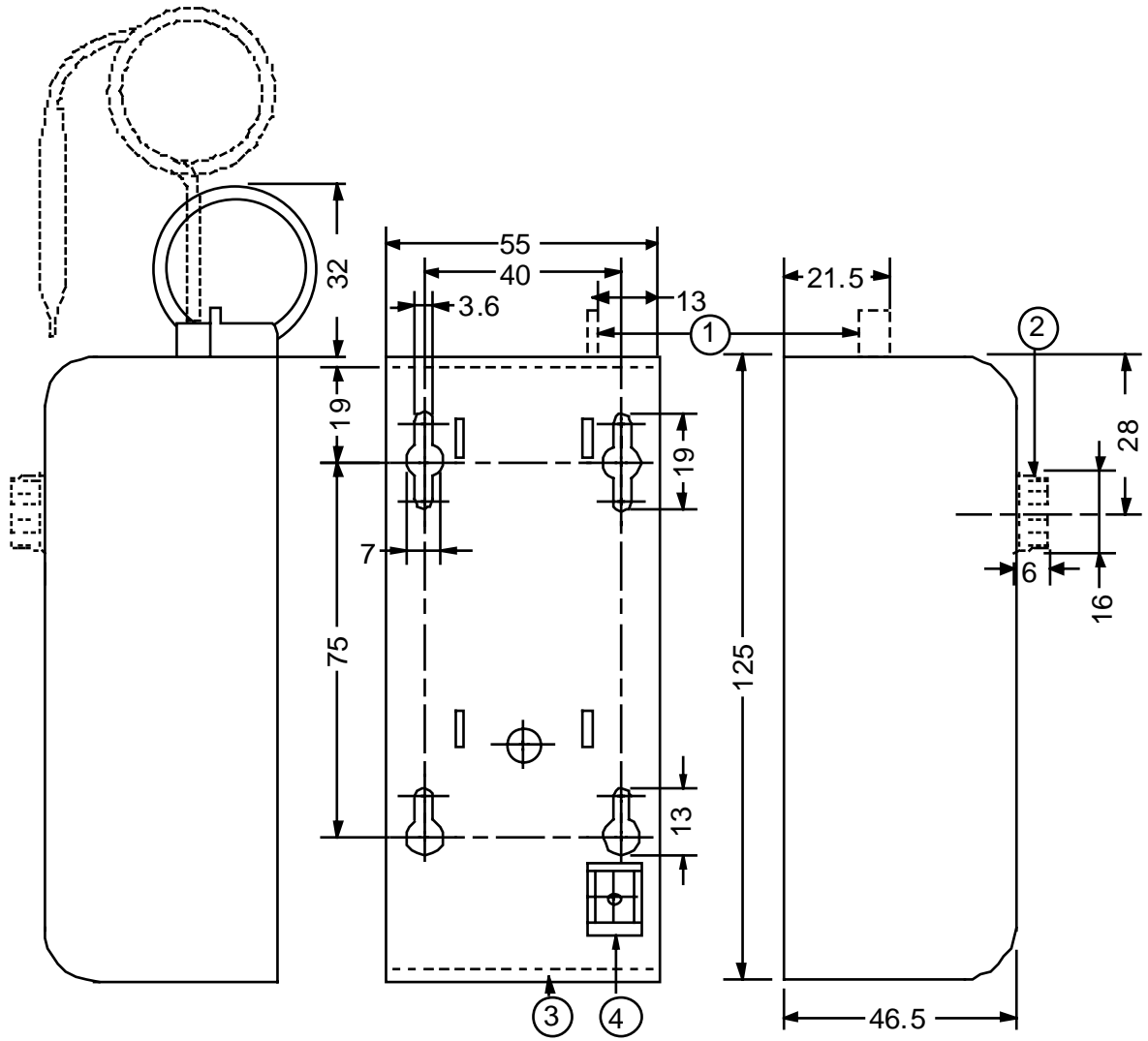

- 1 Reset lever
- 2 Knob packed separately with the control
- 3 22.3 mm dia. cable inlet hole for PG-16
- 4 Earth screw

Fig. 13

Specifications

CE Conformity	According to low voltage directive and EMC directive	
Operating range	-35 to +290 °C. See type number selection table.	
Differential	See type number selection table.	
Differential adjustments	Controls with adjustable differential (types A19ABC and A19BBC) have an adjustment lever under the cover.	
Sensor styles	Styles 1a, 1b, 2, 3, 4h, and 20 (see drawings page 3)	
Electrical ratings	~15(8) A, 230 V; except A19AAF and A19DAF: ~15(3) A 230 V, and A19ABC-9036/9037: ~15(5) A 230 V	
Ambient temp. limits	-35 to +55 °C	
Conduit opening	22.3 mm diam. hole for PG-16 connector	
Material	Case	1.75 mm cold-rolled zinc plated steel
	Cover	1.5 mm ABS plastic
Protection Class	IP30	
Shipping weight	Individual pack	0.4 kg
	Overpack	10 kg (24 pcs)
Dimensions	(see dimension drawing)	

The performance specifications are nominal and conform to acceptable industry standards. For applications at conditions beyond these specifications, consult the local Johnson Controls office or representative. Johnson Controls shall not be liable for damages resulting from misapplication or misuse of its products.



Johnson Controls International, Inc.

Headquarters: Milwaukee, WI, USA
 European Headquarters: Westendhof 8, 45143 Essen, Germany
 European Factories: Lomagna (Italy), Leeuwarden (The Netherlands) and Essen (Germany)
 Branch Offices: Principal European Cities.

This document is subject to change

Printed in Europe