

## Series P77

# Single pressure controls for Refrigeration, Air-conditioning and Heatpump applications

### Product bulletin

These pressure controls are designed for use in a variety of applications involving refrigeration high or low pressure. Models supplied have a "whole range" design, enabling them to be used with refrigerants R22, R134A, R404A, R410A, R744 (CO<sub>2</sub>), R717 (NH<sub>3</sub>), R290, R600 natural HC refrigerants CO<sub>2</sub> and all other non-corrosive refrigerants which are within the operating range of the control. They may also be used for other high or low pressure applications such as air, water etc. Models which can be used with ammonia are included in the program. Also models tested and approved to PED 2014/68/EU Cat. IV (supersedes DIN and TUV approval) are included in the program.

The P77 series pressure controls may be used for control functions or limit functions, depending on model number. All models are provided with alarm contacts. All standard models have phosphor bronze bellows and brass pressure connections. Models for use with ammonia (NH<sub>3</sub>) are provided with stainless steel bellows and connectors. Devices conforming to PED 2014/68/EU Cat. IV (HP models) have the fail-safe function with double bellows.

Their IP54 classification means that these pressure controls are suitable for almost all applications.

P77 Series Controls for Hazardous Location Applications use a low energy signal from inside an explosive zone on commercial refrigeration and air-conditioning applications. The controls have special dry circuit switches with gold-plated contacts for improved contact characteristics required in low voltage, low current circuits.

They are designed to operate in

- Group II, Zone 2 (per the ATEX Directive) environments.
- Class I, Division 2, Group D (per NFPA 70 and CSA C22.2) environments.

- **Gold plated contacts**

For low current applications custom models with gold plated contacts may be requested. Contact your salesman.

- **Generous wiring space**

Easy wiring and maintenance

- **Splash-proof enclosure (IP54)**

Can be used for indoor/outdoor applications

- **SPDT contacts are provided as standard on single pressure controls**

Can be wired for alarm functions

- **Trip-free manual reset**

Override is not possible in the control function

- **ATEX approved**

For use with flammable refrigerants (R290, R600).  
Meets 2014/34/EU ATEX directive.



## Electrical connection hazardous application

Use only cables and cable entries approved for propane applications. Do not allow cables to come into contact with sharp edges. Install cables with adequate stress relief to avoid pulling at the terminal.

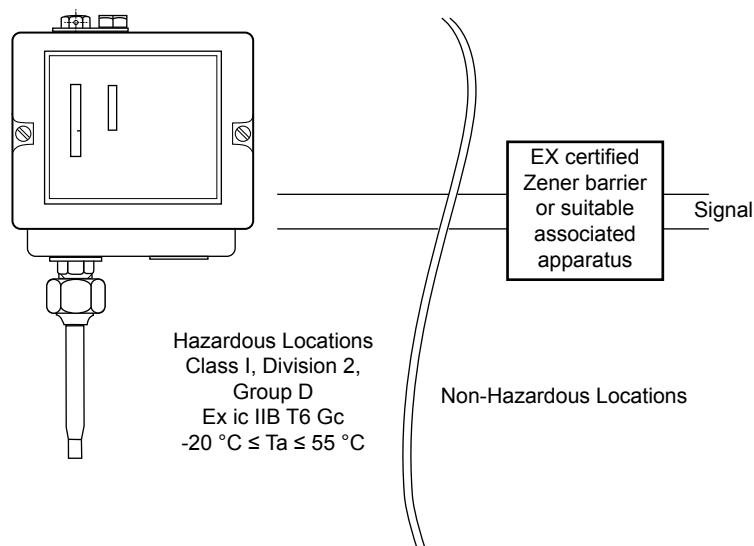

### Intrinsic safety protection method

#### Entity parameters (P77 pressure control parameters)

Maximum switch loads	
Pi max (P max)	1 W
Ui Max (V max)	30 V
Ii Max (I max)	0.1 A
Ci max	0.5 nF
Li max	0.2 μH

Selected associated apparatus providing output entity parameters must be third party listed for the application, and have intrinsically safe entity parameters conforming with table below.

#### Intrinsically safe entity parameters for the associated apparatus

P77 pressure control		Zener barrier or suitable associated apparatus
Ui Max (V max)	≥	Voc or Vt (or Uo)
Ii Max (I max)	≥	Isc or It (or Io)
Pi max (P max)	≥	Po
Ci + Ccable	≤	Ca (or Co)
Li + Lcable	≤	La (or Lo)

**IMPORTANT:** The controls are intended to control equipment under normal operating conditions. Where failure or malfunctioning of the controls could lead to an abnormal operating condition that could cause personal injury or damage to the equipment or other property, other devices (limit or safety controls) or systems (alarm or supervisory systems) intended to warn of or protect against failure or malfunctioning of the controls must be incorporated into and maintained as part of the control system.

### Type number matrix

<b>P77AAA</b>	Automatic reset
<b>P77BCA</b>	Open low - manual reset
<b>P77BEA</b>	Open high - manual reset
<b>P77AAW</b>	HP or LP Limit (autoreset) HP conforming to PED 2014/68/EU
<b>P77BEB</b>	HP Limit (Manual Reset) conforming to PED 2014/68/EU
<b>P77BES</b>	HP Safety Limit (Manual Reset) conforming to PED 2014/68/EU
<b>P77BCB</b>	LP Limit (Manual Reset) including lockplate assy
<b>P77XAAW</b>	HP or LP Limit (autoreset) HP conforming to PED 2014/68/EU HP or LP conforming to ATEX 2014/34/EU

### Mounting

Mounting can easily be done with mounting bracket 271-51L (order separately) or directly on a surface. Mounting holes 4,5 mm Ø and M4 holes are provided.

### Adjustment

Adjustment of range and differential can be done by turning the hexagonal range screw and differential screw. Manual reset models have a range screw only. The adjustment screw can also be locked by a lock plate accessory (KIT023N600). The lock plate is included with those devices which are conform to PED 2014/68/EU Cat. IV.

On all models the scale indicates the high switch point (Except type P77BCA, P77BCB, here the scale indicates the low (cut-out) switch point). The low switch point can be derived by deducting the differential value from the high switch point.

### Repair and replacement

Repair is not possible. In case of an improperly functioning control, please check with your nearest supplier. When contacting the supplier for a replacement you should state the type/model number of the control. This number can be found on the data plate or cover label.

### Contact functions (see also "Type number selection" tables)

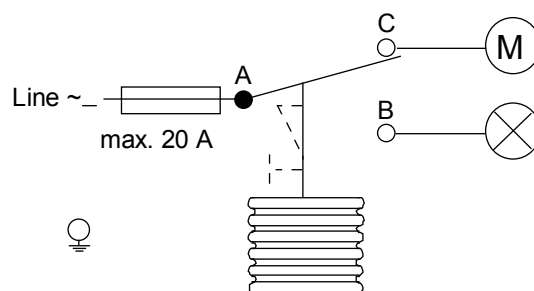

Figure 1: A - C open on pressure decrease

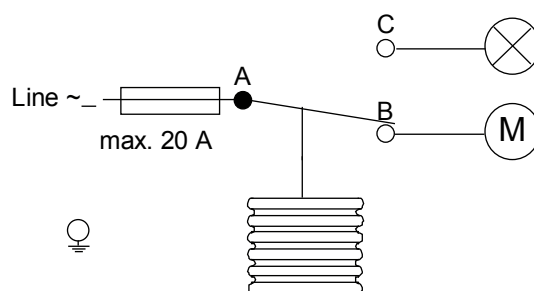

Figure 2: A - B open on pressure increase

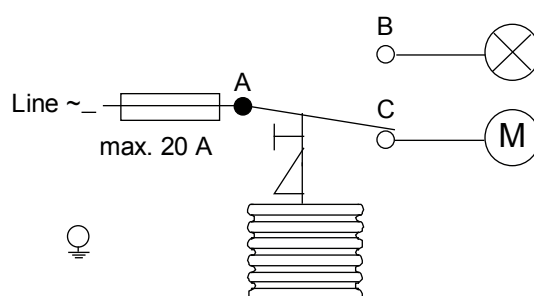

Figure 3: A - C open on pressure increase

### Optional construction note

If your requirements are not in the type number selection table, then please contact your Johnson Controls representative.

## Type number selection

### Pressure controls for non-corrosive refrigerants

Family code	Style 5		Style 28	Style 30	Range (bar)	Diff. (bar)	Contact function (Figure)	Max bellows pressure
	Ind. pack.	Bulkpack	Bulkpack	Ind. pack.				
P77AAA	-9300	-9320	-9800	-9400	-0.5 to 7	0.6 to 3	1	22
	-9301	---	---	---	-0.2 to 10	1 to 4.5	1	15
	-9302	---	---	---	-0.3 to 2	0.4 to 1.5	1	4
	-9350	-9370	-9850	-9450	3 to 30	3 to 12	2	33
	-9351	-9371	---	-9451	3.5 to 21	2.1 to 5.5	2	30
P77BCA	-9300	-9320	---	-9400	-0.5 to 7	Man. res.**	1	22
P77BEA	-9350	-9370	---	-9450	3 to 30	Man. res.*	3	33

\* Resettable at 3 bar below cut-out point

\*\* Resettable at 0.5 bar above cut-out point

### Pressure controls for ammonia and non-corrosive refrigerants

Family code	Style 15		Range (bar)	Diff. (bar)	Contact function (Figure)	Max bellows pressure
	Ind. pack.	Bulkpack				
P77AAA	-9700	---	-0.5 to 7	0.6 to 3	1	14
P77AAA	-9750	---	3 to 30	3.5 to 12	2	33
P77BCA	-9700	---	-0.5 to 7	Man. res.**	1	14
P77BEA	-9750	---	3 to 30	Man. res.*	3	33

\* Resettable at 3 bar below cut-out point

\*\* Resettable at 0.5 bar above cut-out point

**Note:** 100 kPa = 1 bar ≈ 14.5 psi

### Pressure controls for non-corrosive refrigerants

(Pressure limiter, pressure cut-out, safety pressure cut-out, including lockplate assy)

Family code	Style 5		Style 28	Range (bar)	Diff. (bar)	Contact function (Figure)	Max bellows pressure	Approved according to PED 2014/68/EU Cat. IV
	Ind. pack.	Bulkpack	Ind. pack.					
P77AAW	-9300	-9320	-9800	-0.5 to 7	0.6 to 3	1	22	---
	-9350	-9370	-9850	3 to 30	3.5 to 12	2	33	●
	-9355	---	-9855	3 to 42	4 to 12	2	47.6	●
P77BCB	-9300	-9320	-9800	-0.5 to 7	Man. res. **	1	22	---
P77BEB	-9350	-9370	-9850	3 to 30	Man. res. *	3	33	●
	-9355	---	-9855	3 to 42	Man. res. ***	3	47.6	●
P77BES	-9350	-9370	-9850	3 to 30	Man. res. *	3	33	●

\* Resettable at 3.5 bar below cut-out point

\*\* Resettable at 0.5 bar above cut-out point

\*\*\* Resettable at 5 bar below cut-out point

## Type number selection

Pressure controls for ammonia and non-corrosive refrigerants,  
(Pressure limiter, pressure cut-out, safety pressure cut-out, including lockplate assy)

Family code	Style 15		Range (bar)	Diff. (bar)	Contact function (Figure)	Max bellows pressure	Approved according to PED 2014/68/EU Cat. IV
	Ind. pack.	Bulkpack					
P77AAW	-9700	---	-0.5 to 7	0.6 to 3	1	14	---
	-9750	---	3 to 30	3.5 to 12	2	33	●
P77BEB	-9750	---	3 to 30	Man. res.*	3	33	●
P77BES	-9750	---	3 to 30	Man. res.*	3	33	●

\* Resetable at 3.5 bar below cut-out point

Pressure controls for Hazardous Location Application and non-corrosive refrigerants  
(Pressure limiter, including lockplate assy)

Family code	Style 28		Contact function (Figure)	Range (bar)	Differential (bar)	Pressure connection	Maximum bellows pressure	Approved according to PED 2014/68/EU Cat. IV
	Ind. pack.	Bulkpack						
P77XAAW	-18000C	-18000D	1	-0.5 to 7	0.6 to 3	6 mm diam. copper tube	22	---
	-18500C	-18500D	2	3 to 30	3.5 to 12		33	●

## Pressure connection

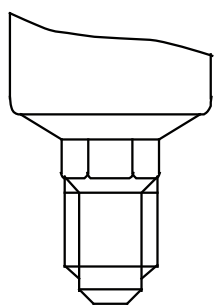

**Style 5**

Male connector  
7/16" - 20 UNF for 1/4  
6 mm flare nut.

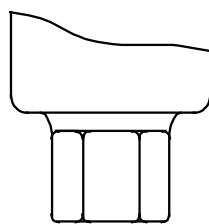

**Style 15**

Female connector  
1/4" - 18 NPT

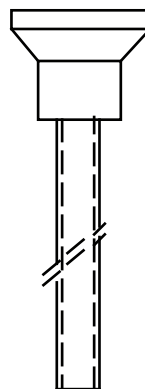

**Style 28**

Braze connection  
6 mm ODM

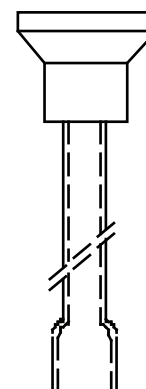

**Style 30**

Braze connection  
1/4 ODF

## Accessories (optional)

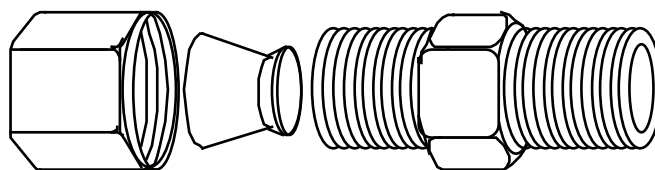

Ordering Codes	Application	Description
<b>CNR003N001R</b>	For 6 mm copper or steel tubing	Fit into style 15 pressure connectors
<b>CNR003N002R</b>	For 8 mm copper or steel tubing	

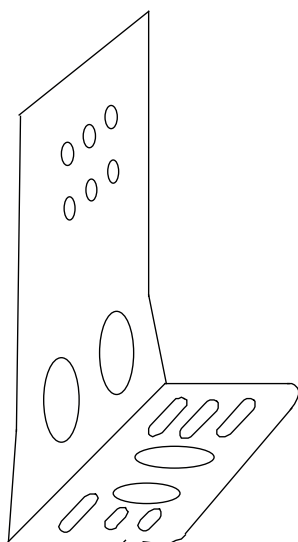

**Mounting bracket**

Order number  
**271-51L**

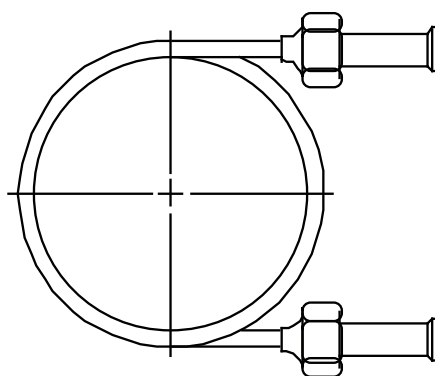

**90 cm Capillary  
with (2) flare nuts (1/4" SAE)**

Order number  
**SEC002N600**

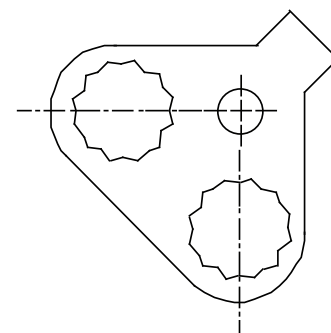

**Locking kit**

Order number  
**KIT023N600**

## Dimensions in mm (Style 5 and style 15)

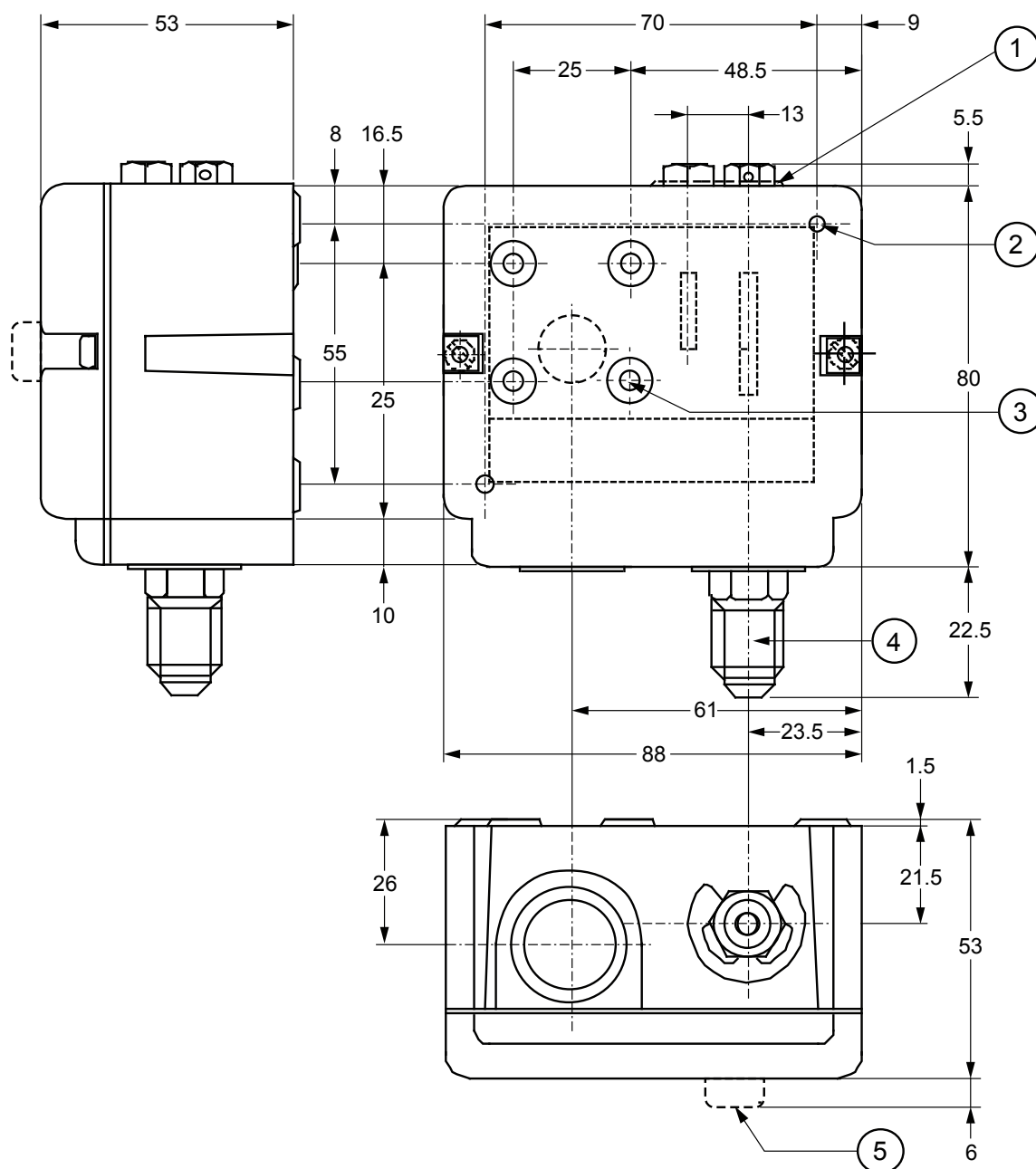

1. Lock plate (if applied)
2. Two mounting holes  $\varnothing$  4.5 mm (knock out)
3. Four mounting holes  $\varnothing$  M4 (back side)
4. Power element: Style 5: 7/16" -20 UNF male (shown)  
Style 15: 1/4" -18 NPT female
5. Reset button

## Dimensions in mm (Style 28 and style 30)

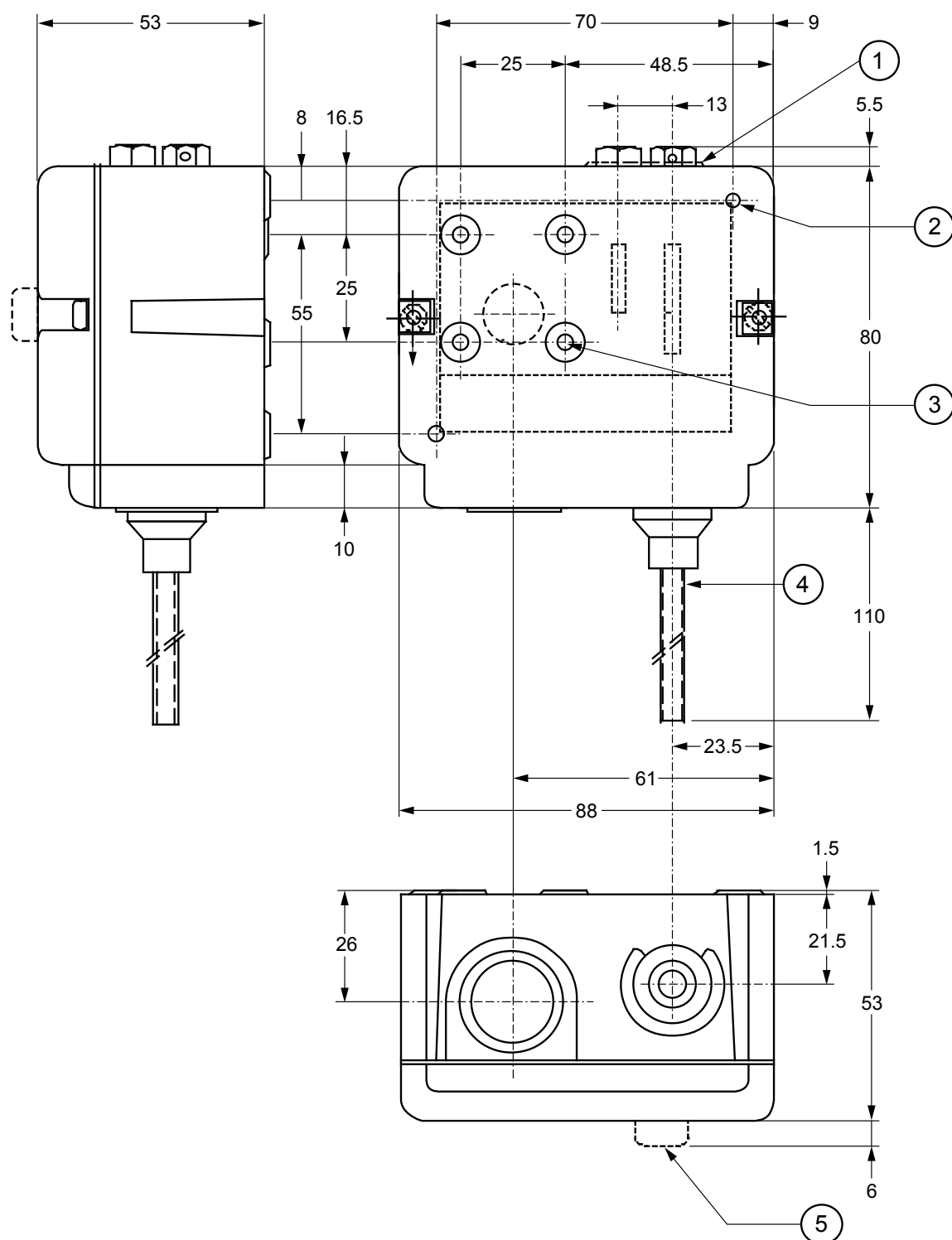

1. Lock plate (if applied)
2. Two mounting holes  $\text{\O} 4.5 \text{ mm}$  (knock out)
3. Four mounting holes  $\text{\O} \text{M4}$  (back side)
4. Power element: Style 28: Braze connection 6 mm ODM (shown)  
Style 30: Braze connection 1/4" ODF
5. Reset button



## Technical specifications

<b>Pressure connections</b>	Style 5, 15, 28, 30 (see drawings)
<b>Operating ranges and diff.</b>	See "Type number selection" tables
<b>Adjustments</b>	See "Type number selection" tables
<b>Ambient temperature limit</b>	-50 to +55 °C (+70 °C max. duration two hours) -20 to +55 °C for PED approved models
<b>Electrical ratings</b>	400 Vac 16(10) A 220 Vdc 12 W (pilot duty only) P77X model: 30 V / 1W
<b>Pulsation plug</b>	Fitted into all HP bellows on models with range 3.5 to 21 bar and up
<b>Locking plate and screw</b>	To lock and seal range and/or differential screw. Standard on types P77AAW, BEB, BES and BCB. Optional on all other types (quantity orders only)
<b>Protection class</b>	IP54
<b>Material</b>	
<b>Case and cover</b>	Weatherproof aluminium (die-cast)
<b>Contact unit</b>	Large silver nickel contact surface
<b>Accessories (see pag. 6)</b>	Mounting bracket Compression coupling 90 cm capillary with two flare nuts
<b>Shipping weight</b>	
	<b>ind. pack</b> 0.5 kg.
	<b>-93xx</b> Ind. overpack 36 pcs. (19 kg)
	<b>-97xx</b> Bulk pack 35 pcs. (18 kg)
	<b>-94xx</b>
	<b>-98xx</b> Ind. overpack 16 pcs. (9 kg)
	<b>-18xx</b>

### Compliance



**Europe** Johnson Controls declares that these products are in compliance with the essential requirements and other relevant provisions of the EMC Directive 2014/30/EU and Low Voltage Directive 2014/35/EU. Pressure Equipment Directive 2014/68/EU. ATEX: DEMKO 16 ATEX 1734 Directive: EN 60079-0 EN 60079-11

**Australia and New Zealand** RCM Mark, Australia/NZ Emissions Compliant

The performance specifications are nominal and conform to acceptable industry standards. For application at conditions beyond these specifications, consult the local Johnson Controls office. Johnson Controls shall not be liable for damages resulting from misapplication or misuse of its products.



### Building Efficiency

Headquarters: Milwaukee, Wisconsin, USA  
Branch Offices: Principal Cities World-wide

Metasys® and Johnson Controls® are registered trademarks of Johnson Controls.  
All other marks herein are the marks of their respective owners.

© Copyright 2017 Johnson Controls. All rights reserved. Any unauthorized use or copying is strictly prohibited.

[www.johnsoncontrols.com](http://www.johnsoncontrols.com)