

Installation guide

Pressure switch

KP 1E, KP 6EW, KP 6EB, KP 7EW, KP 7EB

060R9516

060R9516

Refrigerants:

R290, R32, R444B, R600, R600a, R1234ze, R1290

For complete list of approved refrigerants, visit www.products.danfoss.com and search for individual code numbers, where refrigerants are listed as part of technical data.



This product is validated in accordance to EN 60079-0:2012 + A11:2013.
Ignition risk is evaluated in accordance to EN 60079-11:2012.
See safety requirements at the end of instruction.

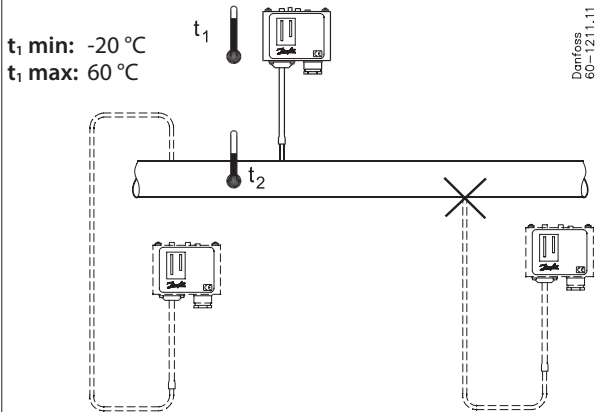
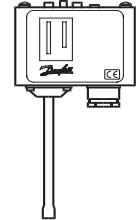

t₁ min: -20 °C
t₁ max: 60 °C

Danfoss
60-1211.11

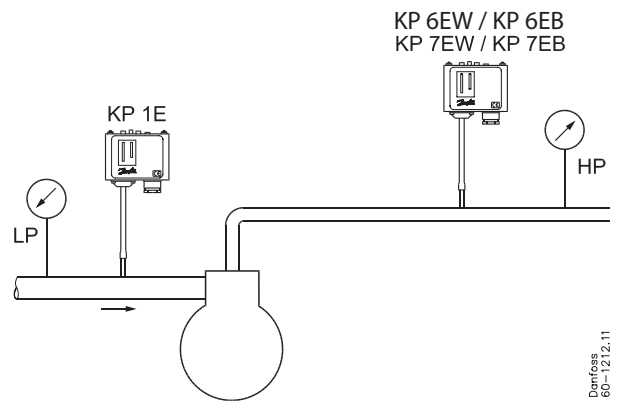

KP 6EW / KP 6EB
KP 7EW / KP 7EB

Danfoss
60-1212.11

Relative humidity RH: 30 – 98%
Vibration resistance: 4g (10 – 1000 Hz)

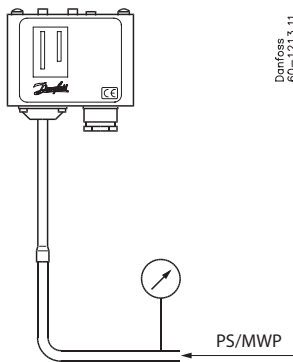

Danfoss
60-1213.11

Pressure	Type	Regulating range [bar]	Differential Δp [bar]	Max. Working Pressure PS/MWP [bar]	Function*	Code no. Connection ¼ in ODF solder
Low	KP 1E	-0.2 - 7.5	0.7 - 4.0	17	PSL	060-530066
Low	KP 1E	-0.9 - 7.0	0.7	17	PZL	060-530266
High	KP 6EW	8 - 42	4 - 10	46.5	PSH	060-522466
High	KP 6EB	8 - 42	4	46.5	PZH	060-522566
High	KP 7EW	8 - 32	1.8 - 6.0	32	PSH	060-530466
High	KP 7EB	8 - 32	4	32	PZH	060-530666

* PSL, PZL, PSH, PZH according to EN12263: 1998

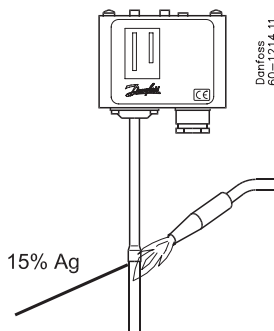

Danfoss
60-1214.11

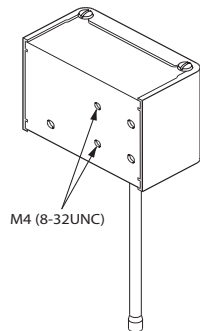

M4 (8-32UNC)

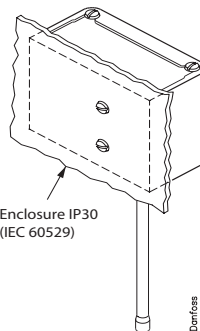

Enclosure IP30
(IEC 60529)

Danfoss
60-1215.11

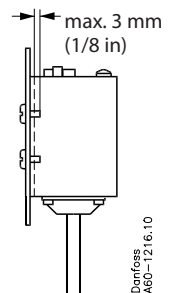

Danfoss
A60-1216.10



Note:
Do not expose to direct sunlight.

Electrical connection

The KP-E pressure switch placed in explosive zone must always be wired through reliable Ex zener barrier, placed outside ex-zone, to ensure insufficient energy supply to cause the ignition of surrounding atmosphere by an electrical spark or the heating of components of circuitry.

Cables and cable entries approved for the application must be used and can not be in contact with sharp edges. Cables must be connected with adequate stress relief that way that pulling forces can not be carried through the cable to the terminal. Use the tightening torque of max. 2 Nm.

The equipment to be used for electrical load limiting must always be approved for use in the zone concerned.

Note:

A particular system can be classified in different zones, for different parts of the system.

Intrinsic safety protection method

EX - zone	Non EX - zone	Electrical data for intrinsically safe specification (for all KP-E types):	Product marking
<p>KP-E</p>	<p>EX certified Zener barrier Signal</p>	<p>Pi max: 1 W Ui max: 30 V Ii max: 0.1 A Ci max: 0.5 nF Li max: 0.2 μH</p>	<p>Ex ic IIB T6Gc</p>

Must be used with certified Ex ic barrier (product matching) satisfying the input parameters.

Contact function

Contact 1-4 opens on pressure drop:

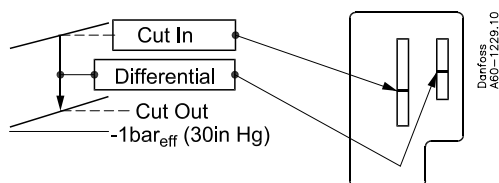
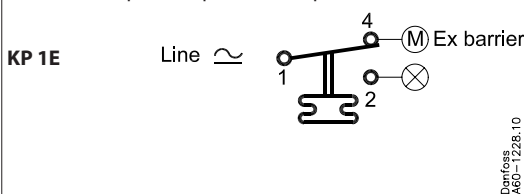

Contact 1-2 opens on pressure rise:

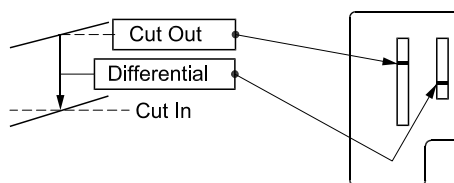
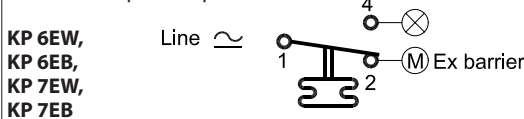

Manual trip function

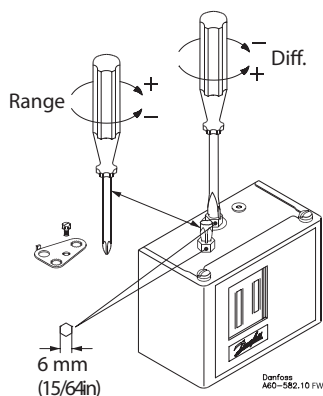
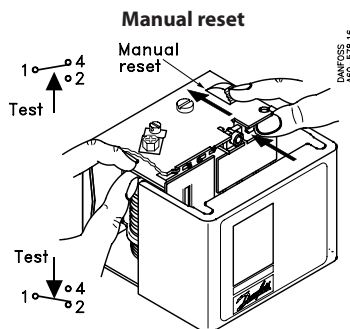
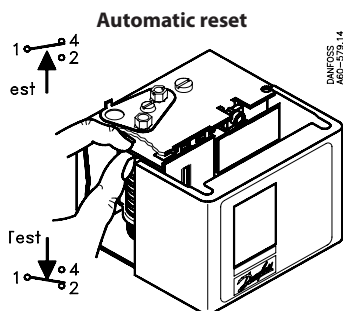



Safety requirements

1. The KP-E can be applied on systems with R290, R32, R444B, R600, R600a, R1234ze, R1290 as the working fluid.
For countries where safety standards are not an indispensable part of the safety system Danfoss recommend the installer to get a third party approval of the system containing flammable refrigerant.
Note, please follow specific selection criteria stated in the datasheet for these particular refrigerants.
2. The refrigeration system must always comply with European Ex installation standard, EN 60079-14, any local directive and legislation as well as any other regulation applying in the area of installation.
3. KP-E switch must be used only with reliable means of limiting the voltage and current to prevent sparks between the contact surfaces. The equipment to be used for electrical load limiting must always be approved for use in the zone concerned.
4. Cable and cable entries approved for the application must be used. Cables must not be in contact with sharp edges. The cable must be connected with adequate stress relief in order to prevent that pulling forces can be carried through the cable to the terminal.
5. In the event of pressure pulsations in the system, where the switch is connected, these must be effectively damped to prevent fatigue failure on the bellows. The cycle frequency of the KP-E switch must be kept as low as possible. The vibration level must be kept as low as possible.
6. It is recommended to regularly check the function of the KP-E switch.
7. Only apparatus designed, constructed and released by Danfoss must be used for application concerned. Danfoss can accept no responsibility in case of alterations made on the pressure switches or the use of them against the instructions of Danfoss.
8. Any overload of the KP-E switch must be prevented. Overloaded or damaged apparatus must be exchanged.
9. Only authorised persons, who are certified in installing and maintaining refrigeration system may do the installation, maintenance and exchange of the switch.
10. Use only appropriate tools.
11. Dispose of the switch in an environmentally-friendly way.
12. KP-E switches must be installed in area where is low risk of mechanical damage.
13. Components within the equipment can exceed the enclosure temperature by 1K (1 °C). When the media temperature exceeds 80 °C, it is the responsibility of the user to ensure that the media temperature does not cause a thermal ignition risk on parts between the media and the switch enclosure thus it is recommended that maximum media temperature on pressure switch is limited to 80 °C.
14. Isolation of the intrinsically safe circuit to ground and to the contact mounting screw has been verified through 500VACrms dielectric strength testing, carried out in accordance with IEC EN 60079-11:2012.
15. The max. applicable length of the cable connected to the KP-E depends on cable capacity and inductivity.
Capacitance and inductivity of the cable together with Ci and Li of KP-E must fit requirements of applied zener barrier.

Danfoss A/S

6430 Nordborg

Denmark

CVR nr.: 20 16 57 15

Telephone: +45 7488 2222

Fax: +45 7449 0949

EU DECLARATION OF CONFORMITY**Danfoss A/S****Refrigeration & Air Conditioning Controls**

declares under our sole responsibility that the

Product category: Pressure switches

Type designation(s): KP1E, KP7EW, KP7EB, KP6EW, KP6EB, KP6ES

Covered by this declaration is in conformity with the following directive(s), standard(s) or other normative document(s), provided that the product is used in accordance with our instructions.

Explosive or Protective Systems Intended for use in Potentially Explosive Atmospheres, Directive 2014/34/EUMarking::

II 3G

Ex ic IIB T6 Gc

Tamb. -20°C to +60°C

Test basis:

EN 60079-0:2012 + A11:2013 Explosive atmospheres, Part 0, Equipment-General requirements

EN 60079-11:2012 Explosive atmospheres, Part 11, Equipment Protection by Intrinsic safety "i".

Pressure Equipment Directive 2014/68/EU

Equipment cat:IV

Notifying Body: TÜV Rheinland, Notified Body No.: 0035.

Test basis: EN 12263:1998 Refrigerating systems and heat pumps – Safety switching devices for limiting the pressure, Requirements and tests.

Conformity assessment: module B (production type), TÜV certificates: 01 202 931-B-10-0003-02 and 01 202 641/B-19 0006 module D, TÜV certificate 01 02 PL/Q-11-0004

RoHS Directive 2011/65/EU and 2015/863/EU

EN 50581:2012 Technical documentation for the assessment of electrical and electronics products with respect to the restriction of hazardous substances

Date: 2019.07.10 Place of issue: Grodzisk Maz.	Issued by  Signature: Name: Piotr Chylaszek Title: Atex Authorized Person	Date: 2019.07.10 Place of issue: Grodzisk Maz.	Approved by  Signature: Name: Lukasz Stasiowski Title: RD&E Manager
--	---	--	---

Danfoss only vouches for the correctness of the English version of this declaration. In the event of the declaration being translated into any other language, the translator concerned shall be liable for the correctness of the translation