

THREADED OUTLET, BSPT

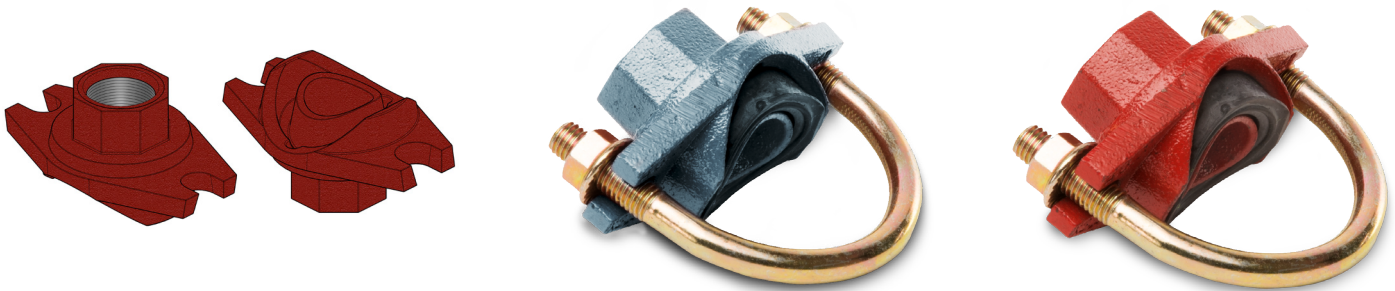

Sprinkler tees are designed for direct connection of sprinkler heads

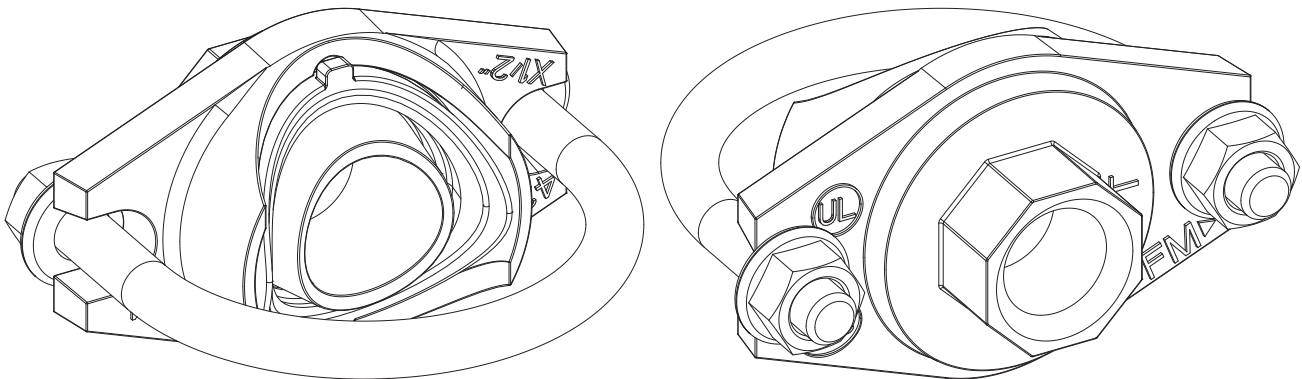

### Material specifications

**Housing:** ductile iron conform to ASTM A536 GR65-45-12

#### Coating

- Hot dip galvanized
- Red paint coating RAL 3000, EPD Epoxy coating

**Rubber gaskets:** EPDM gaskets dispose of the international certifications and have undergone the aging test at 110°C/230°F during a period of 45 days/1080 hours and the frozen test at -40°C/-40°F during a period of 4 days/96 hours

**Bolts and nuts:** see technical datasheet bolts and nuts

### Working pressure

300 PSI/2068 kPa

#### General notes:

- Pressure ratings listed are CWP (cold working pressure) or maximum working pressure within the service temperature range of the gasket used in the coupling. This rating may occasionally differ from maximum working pressure listed and/or approved by UL and/or FM, as testing conditions and test pipes differ. For more information, please contact info@profitings.eu.
- Maximum working pressure listed is total of internal and external pressures, based on standard weight (ANSI) steel pipe and standard roll or cut groove, in accordance with Profit specifications. For more information, please contact info@profitings.eu.
- For one time field test only, the maximum joint working pressure may be increased one and a half times the figure shown.
- Warning: Piping systems must always be depressurized and drained before attempting disassembly and/or removal of any components.
- Profit reserves the right to change specifications, designs and/or standard equipment without notice and without incurring in any obligations.
- Profit red coated products are intended for piping with indoor application (EN 12944-2 corrosivity category C1 & C2). For outdoor installations near the sea (corrosivity category C3) we advise to use our hot dip galvanized couplings and fittings. For application in corrosivity category C4 (higher salinity climate) or higher, please contact info@profitings.eu.
- We strongly advise to always store our products in closed and dry warehouses.

THREADED OUTLET, BSPT

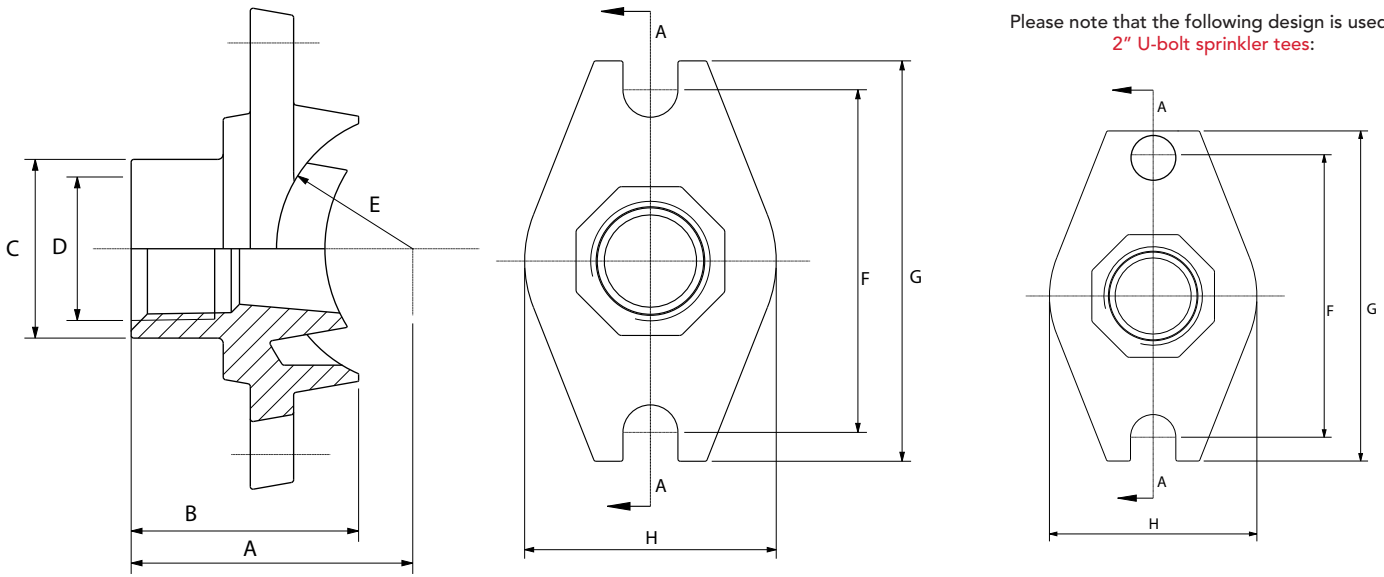

Please note that the following design is used for 2" U-bolt sprinkler tees:

Reference		Nominal size Run x Reducing outlet		Pipe Ø	U-bolt sprinkler tee dimensions								Hole cut	Bolt size	Socket wrench	Bolt torque	Weight
Red	Galva	NPS inch	DN mm	mm	A mm	B mm	C mm	D mm	E mm	F mm	G mm	H mm	mm	d1xL	mm	N*M	kg
GSTR	GSTG	1-½	25-15	33,7 x 21,3	30	30	29	½	17,7	60	74	44	24+1	M8x44	13	25-30	0,20
GSTR	GSTG	1¼-½	32-15	42,4 x 21,3	50	46	28	½	22,2	76	89	56	30+1	M10x78	15	44-54	0,47
GSTR	GSTG	1¼-¾	32-20	42,4 x 26,9	53	49	33	¾	22,2	76	89	56	30+1	M10x78	15	44-54	0,46
GSTR	GSTG	1¼-1	32-25	42,4 x 33,7	58	54	40	1	22,3	76	89	56	30+1	M10x78	15	44-54	0,48
GSTR	GSTG	1½-½	40-15	48,3 x 21,3	49	39	28	½	25,15	76	89	56	30+1	M10x78	15	44-54	0,40
GSTR	GSTG	1½-¾	40-20	48,3 x 26,9	52	42	33	¾	25,16	76	89	56	30+1	M10x78	15	44-54	0,40
GSTR	GSTG	1½-1	40-25	48,3 x 33,7	57	45	40	1	25,16	76	89	56	30+1	M10x78	15	44-54	0,41
GSTR	GSTG	2-½	50-15	60,3 x 21,3	63	36,6	28	½	31,2	78	98	56	30+1	M10x92	15	44-54	0,46
GSTR	GSTG	2-¾	50-20	60,3 x 26,9	63	39,6	33	¾	31,2	78	98	56	30+1	M10x92	15	44-54	0,46
GSTR	GSTG	2-1	50-25	60,3 x 33,7	66	44,6	40	1	31,2	78	98	56	30+1	M10x92	15	44-54	0,47

	M10	M8
h	10	8
s	15	13

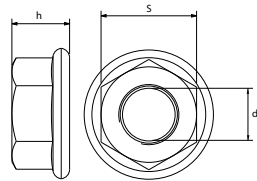

U bolt sprinkler tee
BST
1-1/2
Hole cut dimension 24(+1mm)

**TYVEK LABEL EXAMPLE**

- \* Please note that the **correct hole cut dimension** is mentioned:
  - on the Tyvek label which is attached to the product itself
  - on the document called 'Hole cut dimensions', which is added to each delivery from our warehouse Profit Europe NV, Belgium. This document is attached to the outside of the first box in a plastic pouch with reference 'Documents enclosed'

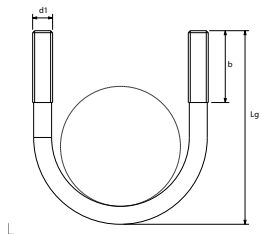

	DN32-40	DN50	DN25
d1	M10	M10	M8
b	32	38	22
Lg	78	93	44

General notes:

- Pressure ratings listed are CWP (cold working pressure) or maximum working pressure within the service temperature range of the gasket used in the coupling. This rating may occasionally differ from maximum working pressure listed and/or approved by UL and/or FM, as testing conditions and test pipes differ. For more information, please contact info@profitings.eu.
- Maximum working pressure listed is total of internal and external pressures, based on standard weight (ANSI) steel pipe and standard roll or cut groove, in accordance with Profit specifications. For more information, please contact info@profitings.eu.
- For one time field test only, the maximum joint working pressure may be increased one and a half times the figure shown.
- Warning: Piping systems must always be depressurized and drained before attempting disassembly and/or removal of any components.
- Profit reserves the right to change specifications, designs and/or standard equipment without notice and without incurring in any obligations.
- Profit red coated products are intended for piping with indoor application (EN 12944-2 corrosivity category C1 & C2). For outdoor installations near the sea (corrosivity category C3) we advise to use our hot dip galvanized couplings and fittings. For application in corrosivity category C4 (higher salinity climate) or higher, please contact info@profitings.eu.
- We strongly advise to always store our products in closed and dry warehouses.